

**CITY OF LAWDALE
CALIFORNIA**

**CONTRACT DOCUMENTS
SPECIFICATIONS AND STANDARD DRAWINGS**

**FOR THE
FY 2023-24 ANNUAL STRIPING PROJECT**



**BID OPENING DATE
APRIL 29, 2024
10:00 AM**

BID OPENING: April 29, 2024, AT 10:00 A.M.

**Public Works Department
4722 Manhattan Beach Boulevard
Lawndale, California 90260
Phone: (310) 973-3260 / Fax: (310) 371-8877**

CITY OF LAWNSDALE

CALIFORNIA

CONTRACT DOCUMENTS,
SPECIFICATIONS AND STANDARD DRAWINGS

FOR THE

FY 2023-24 ANNUAL STRIPING PROJECT

IN AND FOR THE CITY OF LAWNSDALE

Approved by:



Public Works & City Engineering Oversight
Contract Project Manager

Date:03/26/2024

FY 2023-24 ANNUAL STRIPING PROJECT

PUBLIC NOTICE IS HEREBY GIVEN THAT:

Sealed bids will be received at the Office of the City Clerk, Lawndale City Hall, 14717 Burin Avenue, Lawndale, California, 90260, up to the hour of **10:00 a.m., Monday, April 29, 2024**, at which time they will be publicly opened and read aloud in the **City Council Chambers, City Hall, Lawndale, California**, for performing the following work:

FY 2023-24 ANNUAL STRIPING PROJECT

All in accordance with the plans, specifications, and other contract documents on file in the Public Works Department of the City of Lawndale, California. In order for your qualifications to be considered, this office must receive one copy (plus one electronic copy) of your Bid. Bids received after the deadline will not be considered.

The words “**FY 2023-24 ANNUAL STRIPING PROJECT**” shall appear on the envelope of each sealed bid, and each sealed envelope shall be addressed to the City Clerk, City Hall, and Lawndale, California.

MANDATORY INFORMATIONAL PRE-BID MEETING. There will be a Mandatory Informational Pre-Bid meeting on April 8, 2024, at 10:00 am., at the corner of 147th Street and Freeman Avenue. Bidders are strongly encouraged to send an individual who is responsible for the bid, and not a runner. Attendance at the pre-bid job walk is mandatory. Failure to attend the mandatory pre-bid job walk shall be cause for rejection of the bid.

DESCRIPTION OF WORK: The work to be done consists of furnishing all materials, equipment, tools, labor, and incidentals as required in the Plans, Specifications and Contract documents for said project. The work will take place in the City of Lawndale. The scope of work consists of removing and installing thermoplastic crosswalks per Plans and Specifications. This project is subject to compliance monitoring and enforcement by the Department of Industrial Relations.

COMPLETION OF WORK: All work to be done under this contract shall be completed within **SIXTY (60) consecutive calendar days, exclusive of maintenance periods**, beginning on the date stipulated in the written "Notice to Proceed" to be issued by the Engineer.

STATE LABOR STANDARDS & WAGE REQUIREMENTS: In entering into a public works contract, or a subcontract, to supply goods, services, or materials pursuant to a public works contract, the Contractor and all subcontractors agree to follow the State Labor standards. State Labor standards provisions, including prevailing wage requirements, will be enforced such that the general rate of per diem wages (prevailing wage) shall be paid for each craft, classification, or type of worker needed to execute the contract to all workers employed in the execution of the contract. All contractors and subcontractors must furnish electronic certified

payroll records directly to the Labor Commissioner (aka Division of Labor Standards Enforcement) as further described in Article IX of the Agreement. The State General Prevailing Wage Determination is as established by the California Department of Industrial Relations (available at <http://www.dir.ca.gov/DLSR/PWD/index.htm>). The prevailing rate of per diem wages are on file at the City of Lawndale Department of Public Works, 4722 Manhattan Beach Boulevard, Lawndale, California 90266, and are available to any interested party on request.

CONFLICT OF INTEREST: In the procurement of supplies, equipment, construction, and services by sub-recipients, the conflict of interest provisions in 24 CFR 85.36, OMB Circular A-110, and 24 CFR 570.611 shall apply. No employee, officer, or agent of the sub-recipient shall participate in the selection, award, or administration of a contract supported by federal funds if a conflict of interest, real or apparent, would be involved.

ASSIGNMENT: In entering into a public works contract, or a subcontract, to supply goods, services, or materials pursuant to a public works contract, the Contractor, or subcontractor, offers and agrees to assign to the awarding body all rights, title and interest in, and to, all causes of action it may have under Section 4 of the Clayton Act (15 U.S.C. Section 15) or under the Cartwright Act (Chapter 2 [commencing with Section 16700] of Part 2 of Division 7 of the Business and Professions Code), arising from purchases of goods, services, or materials pursuant to the public works contract or the subcontract. This assignment shall be made and become effective at the time the awarding body tenders final payment to the Contractor, without further acknowledgment by the parties.

RETENTION: The City will deduct a five percent (5%) retention from all progress payments as specified in Section 9-3.2 of the Standard Specifications for Public Works Construction. The City in accordance with Public Contract Code Sect. 22300 shall permit the substitution of securities for any moneys withheld by a public agency to ensure performance under a contract. The City hereby incorporates herein all of the provisions set forth in Public Contract Code Sect. 22300.

EXAMINATION OF SITE: Contractor shall examine carefully the site of the proposed work and the contract documents herein. It will be assumed that the Contractor has investigated and is satisfied as to the conditions to be encountered; as to the character, quality, and quantity of the materials to be furnished; and as to the requirements of the contract, specifications, and drawings.

EQUIVALENT MATERIALS: Approval of equipment and materials offered as equivalents to those specified must be obtained in writing from the City. Requests for consideration of equivalents must be submitted in writing allowing five (5) working days for complete consideration of all specifications, samples, references, tests, and other details to the full satisfaction of the City.

INSURANCE: Certificates of insurance in the amounts required shall be furnished by the Contractor to the City and approved by the City prior to the commencement and throughout the duration of the work.

The Contractor and its subcontractors shall maintain insurance in conformance with the requirements set forth below. Contractor will use existing coverage to comply with these requirements. If that existing coverage does not meet the requirements set forth herein, Contractor agrees to amend, supplement, or endorse the existing coverage to do so.

Contractor acknowledges that the insurance coverage and policy limits set forth in this section constitute the minimum amount of coverage required. Any insurance proceeds available to Contractor or its subcontractors in excess of the limits and coverage identified in this Agreement and which is applicable to a given loss, claim or demand, will be equally available to City.

Contractor shall provide the following types and amounts of insurance:

Without limiting Contractor's indemnification of City, and prior to commencement of Work, Contractor shall obtain, provide and maintain at its own expense during the term of this Agreement, policies of insurance of the type and amounts described below and in a form satisfactory to City:

General liability insurance. Contractor shall maintain commercial general liability insurance with coverage at least as broad as Insurance Services Office form CG 00 01, in an amount not less than \$2,000,000 per occurrence, \$2,000,000 general aggregate, for bodily injury, personal injury, and property damage. The policy must include contractual liability that has not been amended. Any endorsement restricting standard ISO "insured contract" language will not be accepted.

Automobile liability insurance. Contractor shall maintain automobile insurance at least as broad as Insurance Services Office form CA 00 01 covering bodily injury and property damage for all activities of the Contractor arising out of or in connection with Work to be performed under this Agreement, including coverage for any owned, hired, non-owned or rented vehicles, in an amount not less than \$1,000,000 combined single limit for each accident.

Umbrella or excess liability insurance. Contractor shall obtain and maintain an umbrella or excess liability insurance that will provide bodily injury, personal injury and property damage liability coverage at least as broad as the primary coverages set forth above, including commercial general liability and employer's liability. Such policy or policies shall include the following terms and conditions:

- A drop down feature requiring the policy to respond in the event that any primary insurance that would otherwise have applied proves to be uncollectable in whole or in part for any reason;
- Pay on behalf of wording as opposed to reimbursement;
- Concurrency of effective dates with primary policies;
- Policies shall "follow form" to the underlying primary policies; and
- Insureds under primary policies shall also be insureds under the umbrella or excess policies.

Workers' compensation insurance. Contractor shall maintain Workers' Compensation Insurance (Statutory Limits) and Employer's Liability Insurance (with limits of at least \$1,000,000) for Contractor's employees in accordance with the laws of the State of California, Section 3700 of the Labor Code. In addition, Contractor shall require each subcontractor to similarly maintain Workers' Compensation Insurance and Employer's Liability Insurance in accordance with the laws of the State of California, Section 3700 for all of the subcontractor's employees.

Contractor shall submit to City, along with the certificate of insurance, a Waiver of Subrogation endorsement in favor of City, its officers, agents, employees and volunteers.

Pollution liability insurance. Environmental Impairment Liability Insurance shall be written on a Contractor's Pollution Liability form or other form acceptable to City providing coverage for liability arising out of sudden, accidental and gradual pollution and remediation. The policy limit shall be no less than \$1,000,000 dollars per claim and in the aggregate. All activities contemplated in this Agreement shall be specifically scheduled on the policy as "covered operations." The policy shall provide coverage for the hauling of waste from the project site to the final disposal location, including non-owned disposal sites.

Products/completed operations coverage shall extend a minimum of three (3) years after project completion. Coverage shall be included on behalf of the insured for covered claims arising out of the actions of independent contractors. If the insured is using subcontractors, the Policy must include work performed "by or on behalf" of the insured. Policy shall contain no language that would invalidate or remove the insurer's duty to defend or indemnify for claims or suits expressly excluded from coverage. Policy shall specifically provide for a duty to defend on the part of the insurer. The City, its officials, officers, agents, and employees, shall be included as insureds under the policy.

The named insureds shall be Contractor and City, including its officers, officials, employees, and agents. All subcontractors (excluding those solely responsible for design Work) of any tier and suppliers shall be included as additional insureds as their interests may appear. Contractor shall not be required to maintain property insurance for any portion of the project following transfer of control thereof to City. The policy shall contain a provision that all proceeds from the builder's risk policy shall be made payable to the City. The City will act as a fiduciary for all other interests in the project.

The policy shall be provided for replacement value on an "all risk" basis for the completed value of the project. There shall be no coinsurance penalty or provisional limit provision in any such policy. The policy must include: (1) coverage for any ensuing loss from faulty workmanship, Nonconforming Work, omission or deficiency in design or specifications; (2) coverage against machinery accidents and operational testing; (3) coverage for removal of debris, and insuring the buildings, structures, machinery, equipment, materials, facilities, fixtures and all other properties constituting a part of the project; (4) Ordinance or law coverage for contingent rebuilding, demolition, and increased costs of construction; (5) transit coverage (unless insured by the supplier or

receiving contractor), with sub-limits sufficient to insure the full replacement value of any key equipment item; (6) Ocean marine cargo coverage insuring any project materials or supplies, if applicable; (7) coverage with sub-limits sufficient to insure the full replacement value of any property or equipment stored either on or off the Site or any staging area. Such insurance shall be on a form acceptable to City to ensure adequacy of terms and sublimits and shall be submitted to the City prior to commencement of construction.

Other provisions or requirements

Proof of insurance. Contractor shall provide certificates of insurance to City as evidence of the insurance coverage required herein, along with a waiver of subrogation endorsement for workers' compensation. Insurance certificates and endorsements must be approved by City's risk manager prior to commencement of performance. Current certification of insurance shall be kept on file with City at all times during the term of this contract. City reserves the right to require complete, certified copies of all required insurance policies, at any time.

Duration of coverage. Contractor shall procure and maintain for the duration of the contract insurance against claims for injuries to persons or damages to property, which may arise from or in connection with the performance of the Work hereunder by Contractor, his agents, representatives, employees or subcontractors. Contractor must maintain general liability and umbrella or excess liability insurance for as long as there is a statutory exposure to completed operations claims. City and its officers, officials, employees, and agents shall continue as additional insureds under such policies.

Primary/noncontributing. Coverage provided by Contractor shall be primary and any insurance or self-insurance procured or maintained by City shall not be required to contribute with it. The limits of insurance required herein may be satisfied by a combination of primary and umbrella or excess insurance. Any umbrella or excess insurance shall contain or be endorsed to contain a provision that such coverage shall also apply on a primary and non-contributory basis for the benefit of City before the City's own insurance or self-insurance shall be called upon to protect it as a named insured.

City's rights of enforcement. In the event any policy of insurance required under this Agreement does not comply with these requirements or is canceled and not replaced, City has the right but not the duty to obtain the insurance it deems necessary and any premium paid by City will be promptly reimbursed by Contractor or City will withhold amounts sufficient to pay premium from Contractor payments. In the alternative, City may cancel this Agreement.

Acceptable insurers. All insurance policies shall be issued by an insurance company currently authorized by the Insurance Commissioner to transact business of insurance or is on the List of Approved Surplus Line Insurers in the State of California, with an assigned policyholders' Rating of A- (or higher) and Financial Size Category Class VII (or larger) in accordance with the latest edition of Best's Key Rating Guide, unless otherwise approved by the City's risk manager.

Waiver of subrogation. All insurance coverage maintained or procured pursuant to this agreement shall be endorsed to waive subrogation against City, its elected or appointed officers, agents, officials, employees and volunteers or shall specifically allow Contractor or others providing insurance evidence in compliance with these specifications to waive their right of recovery prior to a loss. Contractor hereby waives its own right of recovery against City, and shall require similar written express waivers and insurance clauses from each of its subconsultants.

Enforcement of contract provisions (non estoppel). Contractor acknowledges and agrees that any actual or alleged failure on the part of the City to inform Contractor of non-compliance with any requirement imposes no additional obligations on the City nor does it waive any rights hereunder.

Requirements not limiting. Requirements of specific coverage features or limits contained in this Section are not intended as a limitation on coverage, limits or other requirements, or a waiver of any coverage normally provided by any insurance. Specific reference to a given coverage feature is for purposes of clarification only as it pertains to a given issue and is not intended by any party or insured to be all inclusive, or to the exclusion of other coverage, or a waiver of any type. If the Contractor maintains higher limits than the minimums shown above, the City requires and shall be entitled to coverage for the higher limits maintained by the Contractor. Any available insurance proceeds in excess of the specified minimum limits of insurance and coverage shall be available to the City.

Notice of cancellation. Contractor agrees to oblige its insurance agent or broker and insurers to provide to City with a Ninety (90) day notice of cancellation (except for nonpayment for which a ten (10) day notice is required) or nonrenewal of coverage for each required coverage.

Additional insured status. General liability policies shall provide or be endorsed to provide that City and its officers, officials, employees, agents, and volunteers shall be additional insureds under such policies. This provision shall also apply to any excess/umbrella liability policies.

Prohibition of undisclosed coverage limitations. None of the coverages required herein will be in compliance with these requirements if they include any limiting endorsement of any kind that has not been first submitted to City and approved of in writing.

Separation of insureds. A severability of interests provision must apply for all additional insureds ensuring that Contractor's insurance shall apply separately to each insured against whom claim is made or suit is brought, except with respect to the insurer's limits of liability. The policy(ies) shall not contain any cross-liability exclusions.

Pass through clause. Contractor agrees to ensure that its subconsultants, subcontractors, and any other party involved with the project who is brought onto or involved in the project by Contractor, provide the same minimum insurance coverage and endorsements required of Contractor. Contractor agrees to monitor and review all such coverage and assumes all responsibility for ensuring that such coverage is provided in conformity with the requirements of

this section. Contractor agrees that upon request, all agreements with consultants, subcontractors, and others engaged in the project will be submitted to City for review.

Agency's right to revise requirements. The City reserves the right at any time during the term of the contract to change the amounts and types of insurance required by giving the Contractor a ninety (90) day advance written notice of such change. If such change results in substantial additional cost to the Contractor, the City and Contractor may renegotiate Contractor's compensation.

Self-insured retentions. Any self-insured retentions must be declared to and approved by City. City reserves the right to require that self-insured retentions be eliminated, lowered, or replaced by a deductible. Self-insurance will not be considered to comply with these specifications unless approved by City.

Timely notice of claims. Contractor shall give City prompt and timely notice of claims made or suits instituted that arise out of or result from Contractor's performance under this Agreement, and that involve or may involve coverage under any of the required liability policies.

Additional insurance. Contractor shall also procure and maintain, at its own cost and expense, any additional kinds of insurance, which in its own judgment may be necessary for its proper protection and prosecution of the Work.

EMPLOYMENT OF APPRENTICES: Attention is directed to the provisions in Sections 1777.5 and 1777.6 of the California Labor Code concerning employment of apprentices by the Contractor or any Subcontractor under him. The Contractor and any Subcontractor under him shall comply with the requirements of said sections in the employment of apprentices; however, the Contractor shall have full responsibility for compliance with said Labor Code sections for all apprenticeable occupations, regardless of any other contractual or employment relationships alleged to exist.

WAGE RATES: In entering into a public works contract, or a subcontract, to supply goods services, or materials pursuant to a public works contract, the Contractor, or subcontractor, offers and agrees to follow the State Labor standards. State Labor standards provisions, including prevailing wage requirements, will be enforced. The State General Prevailing Wage Determination is as established by the California Department of Industrial Relations (available at <http://www.dir.ca.gov/DLSR/PWD/index.htm>). The general rate of per diem wages (prevailing wage) shall be paid for each craft, classification, or type of worker needed to execute the contract to all workers employed in the execution of the contract. The prevailing rate of per diem wages are on file at the City of Lawndale Department of Public Works, 4722 Manhattan Beach Boulevard, Lawndale, California 90266, and are available to any interested party on request.

SAFETY PERMIT: The Contractor, and not the City, shall be responsible for performing safety inspections for this project. Particular attention is called to Subsection 7-10.4.1 of the Standard Specifications for Public Works Construction, which requires orders issued by the California- Division of Occupational Health and Safety (Cal/OSHA). The Contractor, if needed,

shall secure a permit for excavation and trenching from Cal/OSHA and shall file a copy of such permit with the Engineer prior to commencement of work.

OTHER PERMITS, FEES, AND LICENSES: The Contractor shall, prior to the start of construction, obtain a "**Construction Permit**" from the City. This will be a **NO FEE Permit**. In addition, the Contractor, and **ALL** sub-contractors, **shall possess a City business license** at the time of application for the Construction Permit and for the duration of the contract. The amount of the business license fee may be obtained from the City's Finance Department at (310) 973-3246.

CITY'S RIGHTS RESERVED: The City of Lawndale reserves the right to reject any and all bids or to waive any irregularities or informalities in any bids or in the bidding, should it deem this necessary for the public good, and also the bid of the bidder who has been delinquent or unfaithful in any former contract with the City of Lawndale. No bidder may withdraw his bid for a period of **sixty (60) days** after the date from the opening thereof.

For information on the proposed project and/or bidding requirements, contact [Nabi Sidiqi, Assistant Engineer](#), Department of Public Works, at nsidiqi@lawndalecity.org, or at 310-973-3261

BID QUESTIONS: For the benefit of all proposed bidders, all bid questions shall be submitted by email to Nabi Sidiqi, Assistant Engineer, at nsidiqi@lawndalecity.org. The questions shall be submitted in writing no later than **Wednesday, April 17, 2024 at 2:00 p.m.** for response in advance of bid date.

BID RESULTS: Bid results shall also be available on the City of Lawndale website (<http://www.lawndalecity.org>) within 24 hours after bid opening.

INSTRUCTIONS TO BIDDERS

BID FORM: All bids shall be submitted on the Bid Forms provided herein for the **FY 2023-24 ANNUAL STRIPING PROJECT**, in the City of Lawndale. All information requested therein must be clearly and legibly set forth in the manner and form indicated. The City will not consider any bid not meeting these requirements.

DELIVERY OF BIDS: The bids shall be delivered by the time and to the place stipulated in the "Notice Inviting Sealed Bids." It is the bidder's sole responsibility to see that his bid is received in proper time. Any bid received after the scheduled closing time for receipt of bids will be returned to the bidder unopened. Bidders or their authorized agents are invited to be present at bid opening. It is the responsibility of the bidder to ascertain the issuance of any and all addenda prior to the submittal of his/her bid.

MODIFICATIONS AND ALTERNATIVE BIDS: Unauthorized conditions, limitations, or provisos attached to a bid will render it unresponsive and may cause its rejection. The complete bid forms shall be without alterations or erasures, unless each such correction is suitably authenticated by affixing in the margin immediately opposite the correction the surname or surnames of the person or persons signing the bid. Alternative bids will not be considered unless called for. No oral, telegraphic, or telephonic bid or modifications will be considered.

WITHDRAWAL OF BID: The bid may be withdrawn upon request by the bidder without prejudice to himself prior to, but not after the time fixed for opening of bids, provided that the request is in writing, has been executed by the bidder or his duly authorized representative, and is filed with the City Clerk. **No bid may be withdrawn during the period of sixty (60) days after the opening of bids.**

BID GUARANTY: Each bid shall be accompanied by cash, or a cashier's or certified check, or by a bid bond in the amount of **ten percent (10%)** of the amount named in the bid. Said check or bond shall be made payable to the City of Lawndale and shall be given as a guarantee that the bidder, if awarded the work, will enter into a contract within fifteen (15) days after written notice of the award and will furnish the necessary bonds as hereinafter provided. In case of refusal or failure to enter into said contract, the check or bond, as the case may be, shall be forfeited to the City. No bidder's bond will be accepted unless it conforms substantially to the form furnished by the City, which is bound herein, and is properly filled out and executed.

DISCREPANCIES IN BIDS: In case of discrepancy between numeric and handwritten amounts, the handwritten amount shall prevail. In case of discrepancy between the unit cost and the total set forth for that item, the unit cost shall prevail, provided however, if the amount set forth as a unit cost is ambiguous, unintelligible, or uncertain for any cause, or if is omitted, or in the case of unit basis items, is the same amount as the entry in the "Total Item Amount" column, then the amount set forth in the "Total Item Amount" column for the item shall prevail in accordance with the following:

- (1) As to lump sum items, the amount set forth in the "Total Item Amount" column shall be the item price.

(2) As to unit basis items, the amount set forth in the "Total Item Amount" column shall be divided by the estimated quantity for the item and the price thus obtained shall be the unit costs.

If the "Total Contract Amount" does not equal the sum of the item totals, then the Engineer, after resolving any discrepancy in the item price totals, shall sum the total column and the resultant amount shall be considered the "Total Contract Amount".

COMPETENCY OF BIDDERS: In selecting the lowest responsible bidder, consideration will be given not only to the financial standing but also to the general competency of the bidder for the performance of the work covered by the plans and specification. To this end, each bid shall be supported by a statement of the bidder's experience on the form entitled "**Information Required of Bidder**" bound herein. No bid will be awarded to a Contractor who, at the time of the bid opening and "Award of the Contract", is not licensed in accordance with the laws of the State of California under applicable provisions of the Business and Professions Code or from a Contractor who has failed to demonstrate the attributes of trustworthiness, quality, fitness, capacity and experience to satisfactorily perform the public works contract. The Contractor shall include the Contractor's license number, license classification, and license expiration date on the form furnished herein entitled "Information Required of Bidders." The licensing requirements for Contractors shall apply also to Subcontractors. In addition, any contractor or subcontractor who is ineligible under [Lab C §§1777.1](#) and [1777.7](#) is prohibited from working on this Project.

SUBCONTRACTOR'S LIST: Bidder understands that if he fails to specify a subcontractor for any portion of the work to be performed under the contract, he shall be deemed to have agreed to perform such portion himself and that he shall not be permitted to sublet or subcontract that portion of the work except in cases of public emergency or necessity. In compliance with the provisions of Section 4100 through 4107 of the Public Contract Code of the State of the California and any amendments thereto, the undersigned bidder has set forth on the form provided therefor, the name and location of the place of business of each subcontractor who will perform work or labor or render services to the prime contractor, in or about the construction of or improvements to be performed, under the contract documents to which the attached bid is responsive including special fabrication and installation, and the portion of the work which will be done by each subcontractor for each subcontract in excess of one-half of one percent (1/2%) of this total bid or, in the case of bids for the construction of street and highways, including bridges, in excess of one-half of one percent (1/2%) of this total bid of \$10,000.00, whichever is greater. Additionally, once a subcontractor has been listed in the bid, another subcontractor may not be substituted unless the appropriate statutory procedure is followed and the City consents to the substitution.

BIDDER'S EXAMINATION OF SITE: Each bidder shall examine carefully the site of the proposed work and the contract documents herein. It will be assumed that the bidder has investigated and is satisfied as to the conditions to be encountered; as to the character, quality, and quantity of the materials to be furnished; and as to the requirements of the contract, specifications, and drawings. The name of the individual who examined the site of the work and

the date of such examination shall be stated in the form entitled "Information Required of Bidder" in the space provided therefor.

EQUIVALENT MATERIALS: Approval of equipment and materials offered as equivalents to those specified must be obtained in writing from the City. Requests for consideration of equivalents must be submitted in writing allowing five (5) working days for complete consideration of all specifications, samples, references, tests, and other details to the full satisfaction of the City.

TAXES: No mention shall be made in the bid of Sales Tax, Use Tax, or any other tax, as all amounts bid will be deemed and held to include any such taxes that may be applicable.

DISQUALIFICATION OF BIDDERS: More than one bid from an individual, firm partnership, corporation, or association under the same or different names will not be considered. Reasonable grounds for believing that any bidder is interested in more than one bid for the work contemplated will cause the rejection of all bids in which such bidder is interested. If there is reason for believing that collusion exists among the bidders, all bids will be rejected and none of the participants in such collusion will be considered in future bids. Similarly, failure to comply with the registration requirements of Labor Code Section 1725.5, as further described in the Notice Inviting Bidders, will disqualify a Bidder.

RETURN OF BID GUARANTIES: Within **ten (10) days** after award of the contract, the City will return the bid guaranties made by check accompanying each of the bids except for the three (3) lowest bidders. All other bid guaranties made by check will be held until the contract has been finally executed. They will then be returned to the respective bidders whose bids they accompany. Bid guaranties made by bond shall be void according to the bid bond language, page D-1.

AWARD OF CONTRACT: Bids will be compared on the basis of the lowest possible cost and the contract, if awarded, will be awarded to a responsible bidder whose bid complies with the requirements of these specifications. The award, if made, will be made within **sixty (60) days** after the opening of the bids, provided that the award may be made after said period if the successful bidder shall not have given the City written notice of the withdrawal of his bid.

EXECUTION OF CONTRACT: The bidder to whom award is made shall execute a written contract with the City on the form agreement provided, and shall secure all insurance and bonds as herein provided within **fifteen (15) days** from the date of written notice of the award. Failure or refusal to enter into a contract as herein provided, or to conform to any of the stipulated requirements in connection therewith shall be just cause for the annulment of the award and the forfeiture of the bid guaranty.

If the successful bidder refuses or fails to execute the contract, the City may award the contract to the second lowest responsible bidder. If the second lowest responsible bidder refuses or fails to execute the contract, the City may award the contract to the third lowest responsible bidder. On the failure or refusal of such second or third lowest bidder to execute the contract, such bidder's guaranty shall be likewise forfeited to the City. The work may then be re-advertised.

INSURANCE AND BONDS: Certificates of insurance and the required bonds in the amounts required shall be furnished by the Contractor to the City and approved by the City prior to the commencement of work.

The Contractor shall maintain a policy of workers' compensation insurance on a state approved policy form providing statutory benefits as required under the laws of the State of California for all labor employed by him or by any Subcontractor under him who may come within the protection of such workers' compensation insurance laws. At the time of execution of the contract agreement, the Contractor must provide the City with proof of Contractor's workers' compensation insurance as indicated in these Instructions with employer's liability limits in an amount not less than \$1,000,000.00.

The Contractor shall maintain a policy of commercial general liability insurance to protect said Contractor and the City against loss from liability imposed by law, for damages on account of bodily injury, including death resulting therefrom suffered or alleged to have been suffered by any person or persons, other than employees, resulting directly or indirectly from the performance or execution of this contract or any subcontract thereunder, and also to protect said Contractor and the City against loss from liability imposed by law, for damage to any property, caused directly or indirectly by the performance and execution of this contract or of any subcontract thereunder. Said general liability insurance shall be maintained by the Contractor in full force and effect during the entire period of performance under this contract in the amount of not less than \$2,000,000.00 per occurrence and no less than \$2,000,000.00 general aggregate. The **City of Lawndale and the City's officers, employees and agents** ("City Parties") shall be named as an **"Additional Insureds"** on Contractor's general liability insurance policies. Coverage for an additional insured shall not be limited to its vicarious liability. Defense costs must be paid in addition to limits.

The Contractor shall also maintain a policy of comprehensive automobile liability insurance in an amount not less than \$1,000,000 per accident, combined single limit. Said policy shall include coverage for owned, non-owned, leased and hired cars.

All of the above policies of insurance shall be primary insurance and not contributing with any other insurance available to the City of Lawndale, California, under any third party liability. The general liability policy shall waive all rights of subrogation and contribution it may have against the City and the City's Parties and their respective insurers. Moreover, the insurance policy must specify that where the primary insured does not satisfy the self-insured retention, any additional insured may satisfy the self-insured retention. All of said policies of insurance shall also provide that said insurance may be not cancelled without providing ten (10) days prior written notice by registered mail to the City. In the event any of said policies of insurance are cancelled or amended, Contractor shall, prior to the cancellation or amendment date, submit new evidence of insurance in conformance with these requirements to the City Engineer.

Contractor must require all subcontractors to maintain the same policies of insurance that the Contractor is required to maintain pursuant to this Agreement. The Contractor shall not allow any subcontractor to commence work on this contract until all similar insurance and bonds required of the subcontractor have been obtained.

The Contractor shall secure with a responsible corporate surety or corporate sureties, satisfactory bonds conditioned upon faithful performance by the Contractor, of all requirements under the contract and upon the payment of claims of material supplier and laborers thereunder. The **Faithful Performance Bond** shall be in the sum of not less than **one hundred percent (100%)** of the estimated aggregate amount of the payments to be made under the contract computed on the basis of the prices stated in the bid. The **Payment Bond** (Labor and Material Bond) shall be in the sum of not less than **one hundred percent (100%)** of the estimated aggregate amount of the payments to be made under the contract computed on the basis of the prices stated in the bid.

The payment bond shall contain the original notarized signature of an authorized officer of the surety and affixed thereto shall be a certified and current copy of his power of attorney. **The payment bond shall be unconditional and remain in force during the entire term of the contract** agreement and shall be null and void only if the Contractor completely and faithfully pays all subcontractors and suppliers that have been approved in writing to perform in whole or part the services required herein.

SUFFICIENCY OF INSURER OR SURETY FOR PAYMENT BOND AND PERFORMANCE BOND: All insurers are to be rated A or better according to the most recent Best Rating Guide or The Key Rating Guide, and only if they are of a financial category Class VII or better, unless such requirements are waived by the Risk Manager of the City due to unique circumstances. All sureties shall be admitted surety insurers authorized to do business in the State of California by the Insurance Commissioner. Should the City object to the sufficiency of the insurer or surety the Contractor shall immediately deliver to the City the following documents:

(a) A copy of the “Certificate of Authority” of the Insurer or Surety issued by the Insurance Commissioner, which authorizes the Insurer or Surety to transact surety insurance in the State of California; or

(b) A certificate from the Clerk of the County of Los Angeles that the “Certificate of Authority” of the Insurer or Surety has not been surrendered, revoked, canceled, annulled, or suspended or, in the event the “Certificate of Authority” of the Insurer or Surety has been suspended, that renewed authority has been granted.

Failure of Contractor to timely deliver these documents shall require the City to refrain from entering the agreement, as Contractor will be deemed to have failed to ensure the sufficiency of the Insurer or Surety to the satisfaction of the City, as required by the provisions of the Bond and Undertaking Law, Code of Civil Procedure 995.660. Upon receipt of any bonds, City shall contact the bond company to verify the bond’s validity.

EVIDENCE OF RESPONSIBILITY: Upon the request of the City, a bidder whose bid is under consideration for the award of the contract shall submit promptly to the City satisfactory evidence showing the bidder's financial resources, his construction experience, and his organization and plant facilities available for the performance of the contract.

EMPLOYMENT OF APPRENTICES: Attention is directed to the provisions in Sections 1777.5 and 1777.6 of the California Labor Code concerning employment of apprentices by the Contractor or any Subcontractor under him. The Contractor and any Subcontractor under him shall comply with the requirements of said sections in the employment of apprentices; however, the Contractor shall have full responsibility for compliance with said Labor Code sections for all apprenticeable occupations, regardless of any other contractual or employment relationships alleged to exist.

WAGE RATES: This is a federally assisted construction contract. Contractor and/or all Subcontractors shall pay prevailing wages in accordance with Davis-Bacon and Related Acts at rates not less than those indicated in the "**Notice Inviting Sealed Bids**" section of these specifications.

SAFETY PERMIT: The Contractor, and not the City, shall be responsible for performing safety inspections for this project. Particular attention is called to Subsection 7-10.4.1 of the Standard Specifications for Public Works Construction, which requires orders issued by the California- Division of Occupational Health and Safety (Cal/OSHA). The Contractor, if needed, shall secure a permit for excavation and trenching from Cal/OSHA and shall file a copy of such permit with the Engineer prior to commencement of work.

OTHER PERMITS, FEES, AND LICENSES: The Contractor shall, prior to the start of construction, obtain a "**Construction Permit**" from the City of Lawndale. This will be a **NO FEE Permit**. In addition, the Contractor, and **ALL** sub-contractors, **shall possess a City of Lawndale business license** at the time of application for the Construction Permit and for the duration of the contract. The amount of the business license fee may be obtained from the City's Finance Department at (310) 973-3246.

BID FORM

FIRM NAME: _____

POINT OF CONTACT: _____

ADDRESS: _____

TELEPHONE NUMBER: _____

FAX NUMBER: _____

FOR THE

FY 2023-24 ANNUAL STRIPING PROJECT

CITY OF LAWNSDALE, CALIFORNIA

Definition of Terms (for a complete definition of terms, see California Building Code, 2016 Edition):

CY.....Cubic yard
EAEach
LF.....Linear foot
LS.....Lump sum
SF.....Square foot
SYSquare yard
TONTon

The Contractor hereby agrees to enter into a contract to perform the work and improvements therein mentioned to the satisfaction of and under the supervision of the Engineer of the City of Lawndale, duly appointed for said work in the matter of the construction and installation of **“FY 2023-24 ANNUAL STRIPING PROJECT”** for the sum set forth in the following schedule:

NOTE: The estimated quantities shown herein are approximate. Payment for quantities will be made for actual materials used on the job and based on the unit costs shown below. The City reserves the right to increase or decrease the amount of any quantity shown and to delete all or any item from the contract.

BID SCHEDULE

Bid Schedule					
FY 2023-24 ANNUAL STRIPING PROJECT					
Item No.	Item Description	Unit	Quantity	Unit Price	Total Amount
1.	Mobilization	LS	1		
2.	Traffic Control	LS	1		
3.	Remove and Install 12 Inch Wide Crosswalk Stripe Per CALTRANS Standard Plan A24F (Thermoplastic)	LS	1		
Total Bid Schedule in figures					\$
Total Bid Schedule in Words					

FY 2023-24 ANNUAL STRIPING PROJECT

Signature of Bidder

Dated _____

RESOLUTION OF CONSTRUCTION CLAIMS

(To Be Executed By Contractor)

When a Public Works claim is made to the City, the City will conduct a reasonable review of the claim and, within 45 days, provide the claimant with a written statement identifying what portion of the claim is disputed and what portion is undisputed and both parties shall work to resolve the claim as by Public Contract Code 9204. (A copy of Section 9204 may be found in the Special Provisions, under “Resolution of All Construction Claims”).

Additionally, in all Public Works claims, which may arise between the Contractor and the City which do not exceed the sum of three hundred seventy-five thousand dollars (\$375,000), the requirements of California Public Contract Code, Section 20104 through 20104.6, inclusive, shall apply. (A copy of said Code Sections may be found in the Special Provisions, under “Resolution of Construction Claims of \$375,000 or Less”.) Said Code Sections shall apply for the purpose of filing claims and civil actions for claims as defined in Section 20104 of the Public Contract Code.

The Contractor’s signature is required to verify he/she has reviewed the Code Sections.

Signature of Contractor

Dated _____

BID BOND
(10% of the Bid Amount)

KNOW ALL MEN BY THESE PRESENTS that we _____
as Principal, hereinafter referred to as "Contractor" and _____
as Surety, are held and firmly bound unto the City of Lawndale, hereinafter called the "City," in
the sum of _____
Dollars (\$ _____), for the payment of which sum well and truly to be made, we bind
ourselves, our heirs, executors, administrators, and successors, jointly and severally, firmly by
these presents. The conditions of this obligation are such that whereas the Contractor submitted
to the City a certain Bid, attached hereto and hereby made a part hereof, to enter into a contract
in writing for the _____

_____ ,
and will furnish all required certificates of insurance and bonds as required by the Contract.

NOW, THEREFORE, if said Bid shall be rejected; or in the alternate, if said Bid is accepted,
and the Contractor (i) executes and delivers a contract in the prescribed form of the Agreement,
(ii) delivers certificates evidencing that the required insurance is in effect, (iii) executes and
delivers Performance and Payment Bonds in the forms prescribed, and (iv) in all other respects
performs the agreement created by the acceptance of said Bid, then this obligation shall be void;
otherwise this obligation shall remain in full force and effect, it being expressly understood and
agreed that the liability of the Surety for any and all default of the Contractor hereunder shall be
the amount of this obligation as herein stated. In the event suit is brought upon this bond by City
and judgment is recovered, Surety shall pay all costs incurred by City in said suit, including a
reasonable attorney's fee to be fixed by the court.

The Surety, for the value received, hereby stipulates and agrees that the obligations of said
Surety and its bond shall in no way be impaired or affected by an extension of the time within
which the City may accept such a bid; and said Surety does hereby waive notice of any such
extension.

IN WITNESS WHEREOF, the above-bound parties have executed this instrument under their
several seals this ____ day of _____, 201__, the name and corporate seal of
each corporate party being hereto affixed and these presents duly signed by its undersigned
representative, pursuant to authority of its governing body.

ATTEST:

(Contractor)

(Address)

(By)

(Title)

ATTEST:

(Surety)

(Address)

(By)

(Title)

(To be filled in by Surety):

The rate of premium on this bond is \$_____ per thousand.

The total amount of premium charged is \$_____

NOTARY PUBLIC ATTACH CALIFORNIA ALL-PURPOSE ACKNOWLEDGEMENT

INFORMATION REQUIRED OF BIDDERS

The bidder is required to supply the following information.

(Additional sheets may be attached if necessary.)

- (1) Address: _____
- (2) Telephone: _____ Email: _____
- (3) Type of Firm: _____
(Individual, Partnership, or Corporation)
- (4) Contractor's State License Classification _____ Expiration date _____
- (5) Corporate organized under the laws of the State of: _____
- (6) Is 51% or more of the business owned by: American Indian (), Asian (), Black (), Hispanic (), Female (), Other (Specify) _____.
- (7) List the names and addresses of all members of the firm, or names and titles of all officers of the corporation.

- (8) Number of years of experience as a Contractor in construction work. _____
- (9) List at least three (3) references for projects completed in the last 24 months:

Name	Company	Address and Telephone No. of Client
_____	_____	_____
Name	Company	Address and Telephone No. of Client
_____	_____	_____
Name	Company	Address and Telephone No. of Client
_____	_____	_____

- (10) List the name of the person who inspected the site of the proposed work for your firm:
Date of Inspection: _____

(11) If requested by the City, the Bidder shall furnish a notarized financial statement, financial data, or other information and reference sufficiently comprehensive to permit an appraisal of Bidder's current financial condition.

(12) List the name and address of all **subcontractors who will perform work** in or about the project and indicate what part of the work will be done by each such Subcontractor.

NAME: _____
ADDRESS: _____
LICENSE NO. & CLASS: _____
WORK TO BE PERFORMED: _____

NAME: _____
ADDRESS: _____
LICENSE NO. & CLASS: _____
WORK TO BE PERFORMED: _____

NAME: _____
ADDRESS: _____
LICENSE NO. & CLASS: _____
WORK TO BE PERFORMED: _____

NAME: _____
ADDRESS: _____
LICENSE NO. & CLASS: _____
WORK TO BE PERFORMED: _____

NAME: _____
ADDRESS: _____
LICENSE NO. & CLASS: _____
WORK TO BE PERFORMED: _____

List the name and address of **Major Equipment Suppliers** who will provide equipment or major components for the project.

NAME: _____
ADDRESS: _____
EQUIPMENT TO BE PROVIDED: _____

NAME: _____
ADDRESS: _____
EQUIPMENT TO BE PROVIDED: _____

NAME: _____
ADDRESS: _____
EQUIPMENT TO BE PROVIDED: _____

NAME: _____
ADDRESS: _____
EQUIPMENT TO BE PROVIDED: _____

NAME: _____
ADDRESS: _____
EQUIPMENT TO BE PROVIDED: _____

(13) The Contractor shall furnish the following information concerning bid depository or registry services used in obtaining subcontractor bid figures for this Bid. Additional sheets may be attached if necessary.

A. Were bid depository or registry services used in obtaining subcontractor bid figures in order to compute your bid? Yes () No ()

B. If the answer to "A." is "Yes," forward a copy of the rules of each bid depository you used in the preparation of this Bid.

C. Did you have any source of subcontractor bids other than bid depositories?
Yes () No ()

D. Has any person or group threatened you with subcontractor boycotts, union boycotts, or other sanctions to attempt to convince you to use the services or abide by the rules of one or more bid depositories? Yes () No ()

E. If the answer to "D" is "Yes", please explain the following details:

(a) Date: _____

(b) Name of person or group: _____

(c) Job involved (if applicable): _____

(d) Nature of threats: _____

(e) Additional comments: _____

(TO ACCOMPANY BID)

In accordance with Public Contracting Code Section 10162, the bidder shall complete, under penalty of perjury, the following questionnaire:

QUESTIONNAIRE

Has the bidder, any officer of the bidder, or any employee of the bidder who has a proprietary interest in the bidder, ever been disqualified, removed, or otherwise prevented from bidding on or completing a Federal, State, or local government project because of a violation of law or a safety regulation?

Yes _____ No _____

If the answer is yes, explain the circumstances in the following space:

Note: This questionnaire constitutes a part of the Bid, and a signature on the Bid shall be constituted a signature on this questionnaire.

CONTRACTOR LICENSE AFFIDAVIT

STATE OF CALIFORNIA)
COUNTY OF _____) ss.

_____, being first duly sworn, deposes
Name

and says that he or she is _____ of _____,
Title **Name of Firm**

the party making the foregoing bid, is a licensed Contractor, a duly authorized partner of a Joint Venture which holds a license as a Partnership, or a duly authorized principal and/or representative of a Corporation which holds a license as a Corporation, and that he or she understands the information shown below shall be included with the bid, and understands that any bid not containing this information, or if this information is subsequently proven to be false, shall be considered non-responsive and shall be rejected by the City of Lawndale.

Contractor's State License Number and Classification

License Expiration Date

I certify under penalty of perjury under the laws of the State of California that the foregoing is true and correct.

Subscribed at: _____
(City and County, State)

on _____, 20____.

Signature

State License Number and Classification

Street Address City State Zip Code

Telephone Number

STATE OF CALIFORNIA)
) ss.
COUNTY OF _____)

On _____, 20__, before me, _____, a Notary Public, personally appeared _____, who proved to me on the basis of satisfactory evidence to be the person(s) whose name(s) is/are subscribed to the within instrument and acknowledged to me that he/she/they executed the same in his/her/their

authorized capacity(ies), and that by his/her/their signature(s) on the instrument the person(s), or the entity upon behalf of which the person(s) acted executed the instrument.

I certify under PENALTY OF PERJURY under the laws of the State of California that the foregoing paragraph is true and correct.

WITNESS my hand and official seal.

Signature_____

(Seal)

**NONCOLLUSION DECLARATION TO BE EXECUTED
BY
BIDDER AND SUBMITTED WITH BID**

The undersigned declares:

I am the _____ of _____, the party making the foregoing bid.

The bid is not made in the interest of, or on behalf of, any undisclosed person, partnership, company, association, organization, or corporation. The bid is genuine and not collusive or sham. The bidder has not directly or indirectly induced or solicited any other bidder to put in a false or sham bid. The bidder has not directly or indirectly colluded, conspired, connived, or agreed with any bidder or anyone else to put in a sham bid, or to refrain from bidding. The bidder has not in any manner, directly or indirectly, sought by agreement, communication, or conference with anyone to fix the bid price of the bidder or any other bidder, or to fix any overhead, profit, or cost element of the bid price, or of that of any other bidder. All statements contained in the bid are true. The bidder has not, directly or indirectly, submitted his or her bid price or any breakdown thereof, or the contents thereof, or divulged information or data relative thereto, to any corporation, partnership, company, association, organization, bid depository, or to any member or agent thereof, to effectuate a collusive or sham bid, and has not paid, and will not pay, any person or entity for such purpose.

Any person executing this declaration on behalf of a bidder that is a corporation, partnership, joint venture, limited liability company, limited liability partnership, or any other entity, hereby represents that he or she has full power to execute, and does execute, this declaration on behalf of the bidder.

I declare under penalty of perjury under the laws of the State of California that the foregoing is true and correct and that this declaration is executed on _____ [date], at _____ [city], _____ [state].

AGREEMENT

THIS AGREEMENT, made and entered into by and between the **CITY OF LAWDALE, CALIFORNIA**, hereinafter referred to as the "**City**," and _____ hereinafter referred to as the "**Contractor**,"

WITNESSETH: That the parties hereto do mutually agree as follows:

ARTICLE I: For and in consideration of the payments and agreements hereinafter mentioned to be made and performed by said City, said Contractor agrees with said City to construct the work under the City's specification entitled "**FY 2023-24 ANNUAL STRIPING PROJECT**" and to perform and complete in a good and workmanlike manner all the work pertaining thereto shown on the drawings and described in the specifications herein, to furnish at his own proper cost and expense all tools, equipment, labor, and materials necessary therefor, except such material and equipment as in said specifications as expressly stipulated to be furnished by said City, and to do everything required by this Agreement and the said specifications and drawings.

ARTICLE II: For furnishing all said materials and labor, furnishing and removing all plant, temporary works or structures, tools and equipment and doing all the work contemplated and embraced in this Agreement, also for all loss and damage arising out of the nature of the work aforesaid, or from the action of the elements, or from any unforeseen difficulties which may arise from or be encountered in the prosecution of the work until its acceptance by said City, and for all risks of every description connected with the work; also for all expenses incurred by or in consequence of the suspension or discontinuance of work, except such as in the said specifications are expressly stipulated to be borne by said City, and for well and faithfully completing the work the whole thereof, in the manner shown and described in said drawings and specifications and in accordance with the requirements of the Engineer, said City will pay and said Contractor shall receive in full compensation therefor the prices named in the Bid.

ARTICLE III: All work to be done under this contract shall be completed within **SIXTY (60) consecutive calendar days**, exclusive of maintenance periods, beginning on the date stipulated in the written Notice to Proceed issued by the Engineer. Any changes in time and/or price are to be submitted to the City Engineer, in writing, within 2 days of the occurrence giving rise to the request and shall request a formal decision from the City within 10 days and shall include data supporting the request.

ARTICLE IV: The City hereby promises and agrees with said Contractor to employ, and does hereby employ, said Contractor to provide the materials and to do the work according to the terms and conditions herein contained and referred to for the price aforesaid, and hereby contracts to pay for the same, at the time, in the manner, and upon the conditions set forth in said specifications; and the said parties for themselves, their heirs, executors, administrators, successors, and assigns, do hereby agree to the full performance of the covenants herein contained.

ARTICLE V: The Bid, the Specifications, all contract change orders issued after execution of the Contract Agreement, the General and Special Provisions, all of which are essential parts of this contract, are hereby incorporated in and made part of this Agreement.

ARTICLE VI: Contractor acknowledges and agrees to comply with the provisions of the State Labor Code requiring every employer to pay at least the minimum prevailing rate of per diem wages for each craft, classification, or type of workman needed to execute this contract. State general prevailing wage determination as established by the California Department of Industrial Relations (available at <http://www.dir.ca.gov/DLSR/PWD/index.htm>). The statutory provisions for penalties for failure to pay prevailing wages and/or failure to otherwise comply with state's wage and hour laws will be enforced.

ARTICLE VII: The Contractor shall supply the City with certificates of insurance for the types and amounts of insurance required for this project as described above for this project. Said certificates must comply with all requirements for sufficient insurance as described.

ARTICLE VIII: The Contractor hereby agrees that the Contractor and any subcontractor under him shall pay not less than the general prevailing rate of per diem wages, as determined by the Director of the Department of Industrial Relations, to all workers employed in the execution of this contract as required under Subsection 7-2.2 of the Standard Specifications for Public Works Construction, and shall submit weekly to the City, certified copies of the payroll records for all said workers and shall comply with all statutory requirements relating to certified copies of payroll records, including the maintenance of the records, their certification, and their availability for inspection as required by [Labor Code Section 1776](#) and as required under Subsection 7-2.6 of said Standard Specifications for Public Works Construction. In addition, the Contractor and any subcontractors must furnish electronic certified payroll records directly to the Labor Commissioner (aka Division of Labor Standards Enforcement) in a format prescribed by the Labor Commissioner no less than monthly as follows:

For all new projects Contractors and subcontractors must furnish electronic certified payroll records to the Labor Commissioner.

These new requirements will apply to all public works projects that are subject to the prevailing wage requirements of the Labor Code without regard to funding source.

The applicable prevailing rate of per diem wages are on file at the City of Lawndale Department of Public Works, 4722 Manhattan Beach Boulevard, Lawndale, California 90266, and are available to any interested party on request. The Contractor is required to post at the job site the prevailing rate of per diem wages as determined by the Director of the Department of Industrial Relations and other notices prescribed by regulation.

ARTICLE IX: Contractor shall indemnify, defend with legal counsel approved by City, and hold harmless City, its officers, officials, employees and volunteers from and against all liability, loss, damage, expense, cost (including without limitation reasonable legal counsel fees, expert fees and all other costs and fees of litigation) of every nature arising out of or in connection with Contractor's negligence, recklessness or willful misconduct in the performance of work hereunder or its failure to comply with any of its obligations contained in this Agreement, except

such loss or damage which is caused by the sole or active negligence or willful misconduct of the City. Should conflict of interest principles preclude a single legal counsel from representing both City and Contractor, or should City otherwise find Contractor's legal counsel unacceptable, then Contractor shall reimburse the City its costs of defense, including without limitation reasonable legal counsels fees, expert fees and all other costs and fees of litigation. The Contractor shall promptly pay any final judgment rendered against the City (and its officers, officials, employees and volunteers) with respect to claims determined by a trier of fact to have been the result of the Contractor's negligent, reckless or wrongful performance. It is expressly understood and agreed that the foregoing provisions are intended to be as broad and inclusive as is permitted by the law of the State of California and will survive termination of this Agreement.

Contractor obligations under this section apply regardless of whether or not such claim, charge, damage, demand, action, proceeding, loss, stop notice, cost, expense, judgment, civil fine or penalty, or liability was caused in part or contributed to by an Indemnitee. However, without affecting the rights of City under any provision of this Agreement, Contractor shall not be required to indemnify and hold harmless City for liability attributable to the active negligence of City, provided such active negligence is determined by agreement between the parties or by the findings of a court of competent jurisdiction. In instances where City is shown to have been actively negligent and where City's active negligence accounts for only a percentage of the liability involved, the obligation of Contractor will be for that entire portion or percentage of liability not attributable to the active negligence of City.

ARTICLE X: The City, in accordance with Public Contract Code Section 22300, shall permit the substitution of securities for any moneys withheld by the City to secure performance under a contract. The City hereby incorporates herein all of the provisions set forth in Public Contract Code Section 22300.

ARTICLE XI: In the performance of this agreement, the Contractor shall not engage in, nor permit others he may hire to engage in, discrimination in the employment of persons because of their race, religious creed, color, or national origin, except as provided in Government Code Section 12940. Violation of this provision may result in the imposition of penalties as provided in Labor Code Section 1735.

ARTICLE XII: The Contractor shall maintain accounts and records, including personnel, property, and financial records, adequate to identify and account for all costs pertaining to the contract and such other records as may be deemed necessary by the City to assure proper accounting for all project funds, both federal and non-federal shares. These records will be made available for audit purposes to the City or any authorized representative and will be retained for 3 years after the expiration of this contract, unless permission to destroy them is granted by the City.

ARTICLE XIII: No officer or employee of the City shall have any financial interest in this Agreement nor shall any such officer or employee participate in any decision relating to the Agreement which affects his financial interest or the financial interest of any corporation, partnership or association in which he is interested, in violation of any State statute or regulation.

Similarly, Contractor warrants that it has not paid or given and will not pay or give any third party any money or other consideration for obtaining this Agreement.

ARTICLE XIV: The persons executing this Agreement on behalf of the parties hereto warrant that (i) such party is duly organized and existing, (ii) they are duly authorized to execute and deliver this Agreement on behalf of said party, (iii) by so executing this Agreement, such party is formally bound to the provisions of this Agreement, and (iv) the entering into this Agreement does not violate any provision of any other Agreement to which said party is bound.

ARTICLE XV: Legal actions concerning any dispute, claim or matter arising out of or in relation to this Agreement shall be instituted in the Superior Court of the County of Los Angeles, State of California, or any other appropriate court in such county, and Contractor agrees to submit to the personal jurisdiction of such court in the event of such action.

**CITY: CITY OF LAWDALE,
CALIFORNIA**

Dated _____, 20__

By: _____
CITY MANAGER

ATTEST:

CITY CLERK

Approved as to form:

CITY ATTORNEY

Dated _____, 20__

CONTRACTOR: _____

By: _____
AUTHORIZED REPRESENTATIVE

TITLE

By: _____
AUTHORIZED REPRESENTATIVE

TITLE

(Attach acknowledgment for each
Authorized Representative of Contractor.)

Address: _____

Phone: _____

Fax: _____

Email: _____

**CONTRACTOR'S CERTIFICATE
REGARDING WORKERS' COMPENSATION**

Labor Code Section 3700

"Every employer except the state shall secure the payment of compensation in one or more of the following ways:

(a) By being insured against liability to pay compensation by one or more insurers duly authorized to write compensation insurance in this state.

(b) By securing from the Director of Industrial Relations a certificate of consent to self-insure either as an individual employer, or as one employer in a group of employers, which may be given upon furnishing proof satisfactory to the Director of Industrial Relations of ability to self-insure and to pay any compensation that may become due to his or her employees.

(c) For any county, city, city and county, municipal corporation, public district, public agency, or any political subdivision of the state, including each member of a pooling arrangement under a joint exercise of powers agreement (but not the state itself), by securing from the Director of Industrial Relations a certificate of consent to self-insure against workers' compensation claims, which certificate may be given upon furnishing proof satisfactory to the director of ability to administer workers' compensation claims properly, and to pay workers' compensation claims that may become due to its employees. On or before March 31, 1979, a political subdivision of the state which, on December 31, 1978, was uninsured for its liability to pay compensation, shall file a properly completed and executed application for a certificate of consent to self-insure against workers' compensation claims. The certificate shall be issued and be subject to the provisions of Section 3702.

For purposes of this section, "state" shall include the superior courts of California."

I am aware of the provisions of Section 3700 of the Labor Code, which requires every employer to be insured against liability for workers' compensation or to undertake self-insurance in accordance with the provisions of that code, and I will comply with such provisions before commencing the performance of the work of this contract.

CONTRACTOR

By: _____
AUTHORIZED REPRESENTATIVE

TITLE

(In accordance with Article 5 {commencing at Section 1860}, Chapter 1, Part 7, Division 2, of the Labor Code, the above certificate must be signed and filed with the awarding body prior to performing any work under this contract.)

APPRENTICESHIP REQUIREMENTS

Labor Code, Division 2, Part 7, Chapter 1, Section 1773.3 “Notice; Required information” states:

"(a)(1) An awarding agency shall provide notice to the Department of Industrial Relations of any public works contract subject to the requirements of this chapter, within five (5) days of the award.

(2) The notice shall be transmitted electronically in a format specified by the department and shall include the name of the contractor, any subcontractor listed on the successful bid, the bid and contract award dates, the contract amount, the estimated start and completion dates, job site location, and any additional information the department specifies that aids in the administration and enforcement of this chapter.

(b) In lieu of responding to any specific request for contract award information, the department may make the information provided by awarding bodies pursuant to this section available for public review on its Internet Web site.”

Also note **Labor Code Sections 1776(g), 1777.5 and 1777.7.**

NOTICE

THE CONTRACTOR WILL BE REQUIRED TO FURNISH THE CITY OF LAWDALE WITH THE CLASSIFICATIONS OF LABORERS TO BE USED FOR THE COMPLETION OF THIS PROJECT WITHIN THREE (3) WORKING DAYS AFTER NOTIFICATION OF AWARDING OF CONTRACT.

CITY OF LAWNSDALE

GENERAL PROVISIONS

SCOPE OF WORK: The scope of work consists of furnishing all materials, equipment, tools, labor, and incidentals as required in the Plans, Specifications and Contract documents for said project. The work will take place in the City of Lawnsdale. The scope of work consists of removing and installing thermoplastic crosswalks per Plans and Specifications. This project is subject to compliance monitoring and enforcement by the Department of Industrial Relations.

LOCATION OF WORK: The work will take place at various locations throughout the City of Lawnsdale. Refer to project location map for exact locations.

STANDARD SPECIFICATIONS: California Building Code 2016 Edition.

The Standard Specifications set forth above will control the General Provisions, Construction Materials, and Construction Methods for this Contract, except as amended by the Plans, Special Provisions, or other Contract Documents. The following Special Provisions are supplementary and in addition to the provisions of the Standard Specifications unless otherwise noted and the section numbers of the Special Provisions coincide with those of the said Standard Specifications. Only those sections requiring elaborations, amendments, specifying of the options, or additions are called out.

LEGAL ADDRESS OF CONTRACTOR: The address given in the Contractor's bid on which the contract is founded is hereby designated as the place to which all notices, letters, and other communications to the Contractor shall be mailed or delivered. Unless otherwise required by law, the mailing to or delivering at the above-named place of any notice, letter, or other communication by the City to the Contractor shall be deemed sufficient service thereof upon the Contractor. The date of said service shall be the date of such mailing or delivery. Such address may be changed at any time by a written notice signed by the Contractor and delivered to the Engineer.

RECOVERY OF DAMAGES: The making of an estimate and payment in accordance therewith shall not preclude the City from demanding and recovering from the Contractor such damages as it may sustain by reason of the Contractor's failure to comply with the Specifications.

MONIES MAY BE RETAINED: The City may keep any monies which would otherwise be payable at any time hereunder and apply the same, or so much as may be necessary therefor, to the payment of any expenses, losses, or damages, as determined by the Engineer, incurred by the City, for which the Contractor is liable under the contract.

SALES AND/OR TAXES: Except as may be otherwise specifically provided herein, all sales and/or use taxes assessed by federal, state, or local authorities on materials used or furnished by the Contractor in performing the work hereunder shall be paid by the Contractor.

ALLOWABLE VARIATION: When in these Specifications a maximum or minimum, either in size, percentage, or thickness or relating to quality, character, or other matter, is allowed or prescribed, the work shall be accepted as in compliance if within such maximum or minimum so allowed thereby.

PROTECTION OF PUBLIC UTILITIES: The Contractor shall not be assessed liquidated damages for delay in completion of the project when such delay is caused by failure of the City or owner of a public utility to provide for removal or relocation of existing utility facilities. This Agreement is subject to Government Code Sections 4215 and 4126 – 4216.9. Contractor must notify utilities and obtain an identification number before excavation or be subject to liability for damages to subsurface installations.

EMERGENCY INFORMATION: The names, addresses, and telephone numbers of the Contractor and subcontractors, or their representatives, shall be filed with the Engineer and the County Sheriff's Department prior to beginning work.

EMPLOYMENT OF APPRENTICES: The Contractor's attention is directed to the provisions of Sections 1777.5 and 1777.6 of the Labor Code concerning the employment of apprentices by the Contractor or any Subcontractor under him. The Contractor and any subcontractor under him shall comply with the requirements of all statutory provisions relating to the employment of apprentices. Information relative to apprenticeship standards and administration of the apprenticeship program may be obtained from the Director of Industrial Relations, P.O. Box 603, San Francisco, California 94101 or from the Division of Apprenticeship Standards and its branch offices.

UTILIZATION OF LOCAL BUSINESS AND LABOR: The Contractor is encouraged to make a good faith effort to subcontract with businesses located in the City of Lawndale and to employ Lawndale residents to perform the necessary work relating to this Capital Improvement project. The goal of the City Council is to stimulate business within the City and to provide employment and training for local residents.

PENALTIES FOR DISCRIMINATION IN EMPLOYMENT: Any Contractor who shall be found in violation of the nondiscrimination provisions of the State of California Fair Employment Practices Act or similar provisions of federal law or executive order in the performance of any contract with the City shall be found in material breach of such contract and the City shall have power to cancel or suspend the Contractor, in whole or in part, or to deduct from the amount payable to such Contractor the sum of twenty-five dollars (\$25.00) for each person for each calendar day during which such person was discriminated against, as damages for said breach of contract; or both. Only a finding of the State of California Fair Employment Practices Commission or the equivalent federal agency or officer shall constitute evidence of a violation of contract under this section.

PROVISIONS REQUIRED BY LAW DEEMED INSERTED: Each and every provision of law and clause required by law to be inserted in this contract shall be deemed to be inserted herein, and the contract shall be read and enforced as though it were included herein. If through mistake or otherwise any such provision is not inserted, or is not correctly inserted, then upon application of either party, the contract shall forthwith be physically amended to make such insertion or correction.

PAYROLL RECORDS: The Contractor's attention is directed to the following provisions of Labor Code Section 1776, "Payroll record of wages paid; Inspections; Forms; Effect of noncompliance; Penalties". The Contractor shall be responsible for the compliance with these provisions by his subcontractors.

"(a) Each contractor and subcontractor shall keep an accurate payroll record, showing the name, address, social security number, work classification, straight time and overtime hours worked each day and week, and the actual per diem wages paid to each journeyman, apprentice, worker, or other employee employed by him or her in connection with the public work. Each payroll record shall contain or be verified by a written declaration that it is made under penalty of perjury, stating both of the following:

(1) The information contained in the payroll record is true and correct.

(2) The employer has complied with the requirements of Sections 1771, 1811, and 1815 for any work performed by his or her employees on the public works project.

(b) The payroll records enumerated under subdivision (a) shall be certified and shall be available for inspection at all reasonable hours at the principal office of the contractor on the following basis:

(1) A certified copy of an employee's payroll record shall be made available for inspection or furnished to the employee or his or her authorized representative on request.

(2) A certified copy of all payroll records enumerated in subdivision (a) shall be made available for inspection or furnished upon request to a representative of the body awarding the contract and the Division of Labor Standards Enforcement of the Department of Industrial Relations.

(3) A certified copy of all payroll records enumerated in subdivision (a) shall be made available upon request to the public for inspection or for copies thereof. However, a request by the public shall be made through either the body awarding the contract or the Division of Labor Standards Enforcement. If the requested payroll records have not been provided pursuant to paragraph (2), the requesting party shall, prior to being provided the records, reimburse the costs of preparation by the contractor, subcontractors, and the entity through which the request was made. The public may not be given access to such records at the principal office of the contractor.

(c) Unless required to be furnished directly to the Labor Commissioner in accordance with paragraph (3) of subdivision (a) of Section 1771.4, the certified payroll records shall be on forms provided by the Division of Labor Standards Enforcement or shall contain the same information as the forms provided by the division. The payroll records may consist of printouts of payroll data that are maintained as computer records, if printouts contain the same information as the

forms provided by the division and the printouts are verified in the manner specified subdivision (a).

(d) A contractor or subcontractor shall file a certified copy of the records enumerated in subdivision (a) with the entity that requested the records within 10 days after receipt of a written request.

(e) Except as provided in subdivision (f), any copy of records made available for inspection as copies and furnished upon request to the public or any public agency by the awarding body or the Division of Labor Standards Enforcement shall be marked or obliterated to prevent disclosure of an individual's name, address, and social security number. The name and address of the contractor awarded the contract or the subcontractor performing the contract shall not be marked or obliterated. Any copy of records made available for inspection by, or furnished to, a multiemployer Taft-Hartley trust fund (29 U.S.C. Sec. 175a) shall be marked or obliterated only to prevent disclosure of an individual's full social security number, but shall provide the last four digits of the social security number. Any copy of records made available for inspection by, or furnished to, a joint labor-management committee established pursuant to the federal Labor Management Cooperation Act of 1978 (29 U.S.C. Sec. 175a) shall be marked or obliterated only to prevent disclosure of an individual's social security number.

(f)(1) Notwithstanding any other provision of law, agencies that are included in the Joint Enforcement Strike Force on the Underground Economy established pursuant to Section 329 of the Unemployment Insurance Code and other law enforcement agencies investigating violations of law shall, upon request, be provided nonredacted copies of certified payroll records. Any copies of records or certified payroll made available for inspection and furnished upon request to the public by an agency included in the Joint Enforcement Strike Force on the Underground Economy or to a law enforcement agency investigating a violation of law shall be marked or redacted to prevent disclosure of an individual's name, address, and social security number.

(2) An employer shall not be liable for damages in a civil action for any reasonable act or omission taken in good faith in compliance with this subdivision.

(g) The contractor shall inform the body awarding the contract of the location of the records enumerated under subdivision (a), including the street address, city, and county, and shall, within five working days, provide a notice of a change of location and address.

(h) The contractor or subcontractor has 10 days in which to comply subsequent to receipt of written notice requesting the records enumerated in subdivision (a). In the event that the contractor or subcontractor fails to comply within the 10-day period, he or she shall, as a penalty to the state or political subdivision on whose behalf the contract is made or awarded, forfeit one hundred dollars (\$100) for each calendar day, or portion thereof, for each worker, until strict compliance is effectuated. Upon the request of the Division of Labor Standards Enforcement, these penalties shall be withheld from progress payments then due. A contractor is not subject to

a penalty assessment pursuant to this section due to the failure of a subcontractor to comply with this section.

(i) The body awarding the contract shall cause to be inserted in the contract stipulations to effectuate this section.

(j) The director shall adopt rules consistent with the California Public Records Act (Chapter 3.5 (commencing with Section 6250) of Division 7 of Title 1 of the Government Code) and the Information Practices Act of 1977 (Title 1.8 (commencing with Section 1798) of Part 4 of Division 3 of the Civil Code) governing the release of these records, including the establishment of reasonable fees to be charged for reproducing copies of records required by this section.”

ASSIGNMENT OF ANTITRUST ACTIONS: The Contractor's attention is directed to the following provision of the Public Contracts Code, Section 7103.5, which shall be applicable to the Contractor and his subcontractors:

"(b) In entering into a public works contract or a subcontract to supply goods, services, or materials pursuant to a public works contract, the contractor or subcontractor offers and agrees to assign to the awarding body all rights, title, and interest in and to all causes of action it may have under Section 4 of the Clayton Act (15 U.S.C. Sec. 15) or under the Cartwright Act (Chapter 2 (commencing with Section 16700) of Part 2 Division 7 of Business and Professions Code), arising from purchases of goods, services, or materials pursuant to the public works contract or the subcontract. This assignment shall be made and become effective at the time the awarding body tenders final payment to the contractor, without further acknowledgment by the parties.”

CONSTRUCTION SCHEDULES: Prior to issuing the “Notice to Proceed”, the Engineer will schedule a preconstruction meeting with the Contractor to review the proposed construction schedule and delivery dates, arrange utility coordination, discuss construction methods, and clarify inspection procedures. The Contractor must provide to the Engineer, at the time of the pre-construction meeting, a schedule in the form of a Gantt Chart for review and approval. Any change in the construction schedule will require the Contractor to provide revised charts of those changes to the Engineer within two (2) working days. The "Notice to Proceed" will be issued upon approval of the project schedule. Requests for changes in the schedule shall be submitted by the Contractor to the Engineer in writing for approval at least 48 hours prior to the scheduled operations on the streets affected.

The schedule shall be broken down into activities by street with durations no greater than one week. No more than 15% of the activities may be on the critical path of the baseline schedule. The Engineer will review the baseline schedule and the Contractor will make any reasonable changes requested to make the schedule acceptable.

If at any time project completion is ten or more working days behind schedule, the Contractor shall submit a recovery schedule, subject to approval, showing how the original completion date will be met.

CONSTRUCTION WORKING HOURS: The Contractor's regular hours of work will be from 7:00 AM to 5:00 PM on all work days as defined in Section 6-7.2 (S.S.P.W.C.).

EQUIVALENT MATERIALS: Approval of equipment and materials offered as equivalents to those specified must be obtained in writing from the City. Requests for consideration of equivalents must be submitted in writing allowing five (5) working days for complete consideration of all specifications, samples, references, tests, and other details to the full satisfaction of the City.

SPECIAL PROVISIONS

CITY OF LAWNSDALE

FY 2023-24 ANNUAL STRIPING PROJECT

1. GENERAL

A. THE REQUIREMENT: All work embraced herein shall be accomplished in accordance with the applicable portions of the "Standard Specifications for Public Works Construction" latest edition, plus any supplements, published, herein referred to as "Standard Specifications," except as modified by the General Conditions, these Special Provisions, Standard Drawings and the Project Plans. In addition to the above, the Contractor shall comply with the requirements of the following:

- (1) Bid
- (2) Agreement
- (3) General Provisions
- (4) Special Provisions

B. DEFINITION OF TERMS: Wherever in the Standard Specifications terms are used, they shall be understood to mean and refer to the following:

- (1) City – The City of Lawndale, California
- (2) Council - The Lawndale City Council
- (3) Director, Engineer - The Lawndale Director of Public Works and City Engineer, acting either directly or through authorized agents. Also referred to herein as City Engineer.
- (4) Other terms appearing in the Standard Specifications, the General Conditions, and these Special Provisions shall have the intent and meaning specified in Section 1 of the Standard Specifications.

C. PLANS AND SPECIFICATIONS:

The location of the work, its general nature, extent, form and details of the various features are accompanying and made a part of these specification.

D. COMPLETION OF WORK:

- (1) All work to be done under this contract shall be completed within **SIXTY (60) calendar days**, exclusive of maintenance periods, beginning on the date stipulated in the written "Notice to Proceed" issued by the Engineer.

(2) In the event that the Engineer is of the opinion that the work is being inadequately or improperly prosecuted in any respect, he may demand that the Contractor improve or change the prosecution of the work in such manner as to assure proper and timely completion.

E. FINAL INVOICE AND PAYMENT:

(1) Whenever in the opinion of the Engineer the Contractor shall have completely performed the contract on his part, the Engineer shall notify the City that the contract has been completed in its entirety. He shall request that the City accept the work and that the City Clerk be authorized to file, on behalf of the City, in the office of the Los Angeles County Recorder, a notice of completion of the work herein agreed to be done by the Contractor. The Contractor will then submit to the Engineer for approval a written statement of the final quantities of contract items for inclusion in the final invoice. Upon receipt of such statement, the Engineer shall check the quantities included therein and shall authorize the Contractor to submit an invoice which in the Engineer's opinion shall be just and fair, covering the amount and value of the total amount of work done by the Contractor, not including the work that has already been invoiced by the Contractor. City will pay this invoice less any amounts City is required to withhold as described elsewhere in the Contract Documents.

(2) On the expiration of sixty (60) calendar days after recordation of the acceptance of the project by Los Angeles County Recorder, the City shall pay to the Contractor the amount remaining after deducting from the amount or value stated in the invoice all prior payments to the Contractor and all amounts to be kept and retained under the provisions of the contract and 150% of all disputed amounts. The City will comply with Public Contract Code Section 7107 and other applicable law regarding the release of retention.

F. RETENTION: The City will deduct a five percent (5%) retention from all progress payments as specified in Section 9-3.2 of the Standard Specifications for Public Works Construction.

G. SUBSTITUTION OF SECURITIES FOR RETENTION: Public Contract Code Section 22300 is hereby incorporated by reference. The substitution of securities for any moneys withheld by a public agency to ensure performance under a contract shall be permitted by the City.

H. NO PERSONAL LIABILITY: No agent of the City of Lawndale shall be personally responsible for any liability arising under the contract. No claim shall be made or filed, and neither the City nor any of its agents shall be liable for, or held to pay money, except as specifically provided in the contract.

I. UNPAID CLAIMS: If, upon or before the completion of the work herein agreed to be performed or at any time prior to the expiration of the period within which claims of lien may be filed for record as prescribed by Civil Code Section 8416, any person or persons claiming to have performed any labor or furnished any material, supplies, or services toward the performance or

completion of this contract or that they have agreed to do so, shall file with the City a verified statement of such claim, stating in general terms the kind of labor and materials and the name of the person to or for whom the same was done or furnished, or both, and the amount in value, as near as may be, of that already done or furnished, or both, together with a statement that the same has not been paid, or if any person or persons shall bring against the City or against any agent or agents thereof any action to enforce such claim, the City shall until the discharge thereof withhold from the moneys under its control so much of said moneys due or to become due the Contractor under this contract as shall be sufficient to satisfy and discharge the amount in such notice or under such action claimed to be due, together with the costs thereof; provided, that if the City shall in its discretion permit the Contractor to file such additional bond as is authorized by Civil Code Section 9364 in a sum equal to 125% of the amount of the claim, said moneys shall not thereafter be withheld on account of such claim.

J. NOISE CONTROL REQUIREMENTS: The Contractor shall comply with all local sound control and noise level rules, regulations, and ordinances that apply to any work performed pursuant to the contract.

Each internal combustion engine, used for any purpose on the job or related to the job, shall be equipped with a muffler of a type recommended by the manufacturer. No internal combustion engine shall be operated on the project without said muffler. The noise level from the Contractor's operations, between the hours of 7:00 A.M. and 5:00 P.M., shall not exceed 86 dBA at a distance of fifty (50) feet. This requirement in no way relieves the Contractor from responsibility for complying with the City Code Chapter 8.20 "Noise Control" regulating noise level. Said noise level requirements shall apply to all equipment on the job or related to the job, including but not limited to trucks, transmit mixers, or transient equipment that may or may not be owned by the Contractor. The use of loud sound signals shall be avoided in favor of light warnings except those required by safety laws for the protection of personnel.

Full compensation for conforming to the requirements of this section shall be considered as included in the unit cost for the various contract items of work involved, and no additional compensation will be allowed therefor.

K. PERMITS AND LICENSES: The Contractor shall procure all permits and licenses, pay all charges and fees, and give all notices necessary and incident to the due and lawful prosecution of the work. The Contractor shall also ensure that all subcontractors obtain required permits and licenses.

The Environmental Quality Act of 1970 (Chapter 1433, Stats. 1970), as amended by Chapter 1154, Stats. 1972, may be applicable to permits, licenses, and other authorizations which the Contractor must obtain from local agencies in connection with performing the work of the contract. The Contractor shall comply with all applicable environmental laws and regulations and conditions on the project in obtaining such permits, licenses, and other authorizations, and they shall be obtained in sufficient time to prevent delays to the work, and in undertaking the construction of the project. Contractor shall also comply with all applicable mandatory standards and policies relating to energy efficiency.

In the event that the City has obtained permits, licenses, or other authorizations applicable to the work in conformance with the requirements in said Environmental Quality Act of 1970, the Contractor shall comply with the provisions of said permits, licenses, and other authorizations.

L. PAYMENTS: Attention is directed to Subsection 9-3 of the Standard Specifications for partial payment and final payment requirements. No partial payment will be made for any materials on hand which are furnished but not incorporated in the work.

M. LEGAL ACTIONS AGAINST THE CITY: In the event litigation is brought against the City concerning compliance by the City with State or Federal laws, rules, or regulations applicable to highway work, the provisions of this section shall apply.

(1) If, pursuant to court order, the City prohibits the Contractor from performing all or any portion of the work, the delay will be considered a right of way delay within the meaning of Subsection 6-6 of the Standard Specifications unless the contract is terminated as hereinafter provided, in which event compensation payable to the Contractor shall be determined in accordance with said termination provisions.

(2) If, pursuant to court order (other than an order to show cause) the City is prohibited from requiring the Contractor to perform all or any portion of the work, the City may, if it so elects, eliminate the enjoined work pursuant to Section 3 of the Standard Specifications or terminate the contract in accordance with Subsections 6-3 and 6-5 of the Standard Specifications.

(3) If the final judgment in the action prohibits the City from requiring the Contractor to perform all or any portion of the work, the City will either eliminate the enjoined work pursuant to Section 3 of the Standard Specifications or terminate the contract in accordance with Subsections 6-3 and 6-5 of the Standard Specifications.

(4) Termination of the contract and the total compensation payable to the Contractor in the event of termination shall be governed by the following:

(a) The Engineer will issue the Contractor a written notice specifying that the contract is to be terminated. Upon receipt of said written notice and, except as otherwise directed in writing by the Engineer, the Contractor shall:

[1] Stop all work under the contract, except that portion of the work specifically directed to be completed prior to acceptance.

[2] Perform work the Engineer deems necessary to secure the project for termination.

[3] Remove equipment and plan from the site of the work.

[4] Take such action as is necessary to protect materials from damage.

[5] Notify all Subcontractors and suppliers that the contract is being terminated and that their contracts of orders are not to be further performed unless otherwise authorized in writing by the Engineer.

[6] Provide the Engineer with an inventory list of all materials previously produced, purchased, or ordered from suppliers for use in the work and not yet used in the work, including its storage location and such other information as the Engineer may request.

[7] Dispose of materials not yet used in the work as directed by Engineer. It shall be the Contractor's responsibility to provide the City with good title to all materials purchased by the City hereunder, including materials for which partial payment has been made as provided in Subsection 9-3.2 of the Standard Specifications, and with bills of sale or other documents of title for such materials.

[8] Subject to the prior written approval of the Engineer, settle all outstanding liabilities and all claims arising out of subcontracts or orders for materials terminated hereunder. To the extent directed by the Engineer, the Contractor shall assign to the City all the right, title, and interest of the Contractor under subcontracts or orders for materials terminated hereunder.

[9] Furnish the Engineer with the documentation required to be furnished by the Contractor under the provisions of the contract including, on projects as to which Federal funds are involved, all documentation required under the Federal requirements included in the contract.

[10] Take such other actions as the Engineer may direct.

(b) Acceptance of the contract as hereinafter specified shall not relieve the Contractor of responsibility for damage to materials except as follows:

[1] The Contractor's responsibility for damage to materials for which partial payment has been made as provided in Subsection 9-3.2 of the Standard Specifications, and for materials furnished by the City for use in the work and unused, shall terminate when the Engineer certifies that such materials have been stored in the manner and at the locations he has directed.

[2] The Contractor's responsibility for damage to materials purchased by the City subsequent to the issuance of the notice that the contract is to be terminated shall terminate when title and delivery of the materials has been taken by the City.

[3] When the Engineer determines that the Contractor has completed the work under the contract directed to be completed prior to termination and

such other work as may have been ordered to secure the project for termination, he will recommend that the Engineer formally accept the contract, and immediately upon and after such acceptance by the Engineer, the Contractor will not be required to perform any further work thereon and shall be relieved of his contractual responsibilities for injury to persons or property which occurs after the formal acceptance of the project by the Engineer.

(c) The total compensation to be paid to the Contractor shall be determined by the Engineer on the basis of the following:

[1] The reasonable cost to the Contractor, without profit, for all work performed under the contract, including mobilization, demobilization, and work done to secure the project for termination. Reasonable cost will include a reasonable allowance for project overhead and general administrative overhead not to exceed a total of seven percent (7%) of direct costs of such work.

When in the opinion of the Engineer, the cost of a contract item of work is excessively high due to costs incurred to remedy or replace defective or rejected work, the reasonable cost to be allowed will be the estimated reasonable cost of performing such work in compliance with the requirements of the plans and specifications and the excessive actual cost shall be disallowed.

[2] A reasonable allowance for profit on the cost of the work performed as determined under Subsection (a), provided the Contractor establishes to the satisfaction of the Engineer that it is reasonably probable that he would have made a profit had the contract been completed and provided further that the profit allowed shall in no event exceed four percent (4%) of said cost.

[3] The reasonable cost to the Contractor of handling material returned to the vendor, delivered to the City, or otherwise disposed of as directed by the Engineer.

[4] A reasonable allowance for the Contractor's administrative costs in determining the amount payable due to termination of the contract.

All records of the Contractor and his subcontractors, necessary to determine compensation in accordance with the provisions of this section, shall be open to inspection or audit by representatives of the City at all times after issuance of the notice that the contract is to be terminated and for a period of three years, and such records shall be retained for that period.

After acceptance of the work by the Engineer, the Engineer may make payments on the basis of interim estimates pending issuance of the Final Estimate when in his opinion the amount thus paid, together with all amounts previously paid, will not result in total compensation in excess of that to which the Contractor will be entitled. All payments, including payment upon the Final Estimate, shall be subject to deduction for prior payments and amounts, if any, to be kept or retained under the provisions of the contract.

The provisions of this section shall be included in all subcontracts.

N. CHANGES IN WORK:

Subsection 3-2.2 is hereby deleted and replaced with the following:

“3-2.2 Payment.

The City reserves the right to increase or decrease the amount of any quantity shown and to delete any items from the contract.

When extra work is to be paid on a force account basis, the labor, materials, equipment rental, and other items of expenditures, the percentage of markup applied to the Contractor's direct cost for all overhead and profit shall be in accordance with the following:

Labor	20%
Materials	15%
Equipment Rentals	15%
Other Items and Expenditures	15%”

O. CONTROL OF MATERIALS:

4-1 MATERIALS AND WORKMANSHIP

4-1.1 General. The Contractor and all subcontractors, suppliers, and vendors shall guarantee that all work performed under this contract fully meets the requirements thereof as to quality of workmanship. Should any defects become evident within a period of one year from the date of the acceptance of the work by the City Council, the Contractor shall, at his own expense, make any repair or replacement necessary to restore the work to full compliance with these Special Provisions.

Such repair and replacement shall be made promptly upon receipt of written notice from the Engineer. If the Contractor fails to make such repair and replacement promptly, the Engineer may cause the work to be done and the costs incurred thereby shall become the liability of the Contractor and his Surety.

If, in the opinion of the Engineer, defective work creates a dangerous condition or requires immediate correction or attention to prevent further loss by the City or to prevent interruption of operations of the City, the City will attempt to give the notice required by this article. If the Contractor cannot be contacted or does not comply with the Engineer's request for correction within a reasonable time as determined by the Engineer, the City may, notwithstanding the provisions of this article, proceed to make such correction or attention and the costs of such correction or attention shall be charged against the Contractor.

The foregoing obligation shall be secured by the surety bond in a form approved by the Engineer in an amount not less than ten (10%) of the final contract price or \$1,000.00, whichever is greater, and shall be delivered to the Engineer prior to final acceptance of the work. Payment for fulfilling the requirements of this section shall be considered as included in the unit cost for the various contract items of work, and no additional compensation will be allowed therefor.

4-1.4 Test of Materials. Except as elsewhere specified, the City will bear the cost of testing material and/or workmanship that meets or exceeds the requirements indicated in the project specifications contained herein, Standard Specifications and the Special Provisions. The cost of all other tests, including the retesting of material or workmanship that fails to pass the first test, shall be borne by the Contractor.

4-1.5 Certification. A Certificate of Compliance shall be furnished prior to the use of any materials for which these specifications or the special provisions require that such a certificate be furnished. In addition, when so authorized in these specifications or in the Special Provisions, the Engineer may permit the use of certain materials or assemblies prior to sampling and testing if accompanied by a Certificate of Compliance. The certificate shall be signed by the manufacturer of the material or the manufacturer of assembled materials and shall state that the materials involved comply in all respects with the requirements of the specifications. A Certificate of Compliance shall be furnished with each lot of material delivered to the work and the lot so certified shall be clearly identified in the certificate.

4-1.6 Trade Names or Equals. Approval of equipment and materials offered as equivalents to those specified must be obtained, in writing.

P. LIQUIDATED DAMAGES: Section 6-9 of the Standard Specifications is hereby amended as follows:

“(1) Time is of the essence with respect to the performance by Contractor of its duties. Failure of the Contractor to complete the work within the time allowed will result in damages being sustained by the City. Such damages are, and will continue to be, impracticable and extremely difficult to determine. For each consecutive calendar day, or portion thereof, in excess of the time specified for completion of the work (as adjusted), the

Contractor shall pay to the City, or the City may deduct from any payments due or to become due to Contractor, the sum of \$500.00.

Execution of the contract under these specifications shall constitute agreement by the City and the Contractor that the specified liquidated damages per day is the minimum value of the costs and actual damage caused by the failure of the Contractor to complete the work within the allotted time, that such sum is liquidated damages and shall not be construed as a penalty, and that such sum may be deducted from payments due the Contractor if such delay occurs.”

Q. CONFERENCES AND MEETING: When and as directed by the Engineer, the Contractor shall attend all conferences and meetings that the Engineer deems necessary for the proper progress of work under this contract.

R. UNDERGROUND SERVICE ALERT: Except in an emergency, the Contractor, prior to conducting any excavation or resurfacing, shall contact the appropriate regional notification center, at least two working days prior to commencing that excavation or resurfacing. The regional notification center shall provide an inquiry center and shall notify any member, if known, who has a subsurface installation in the area of the proposed excavation or resurfacing.

Underground Service Alert may be contacted by calling 1-800-422-4133.

S. RESOLUTION OF ALL CONSTRUCTION CLAIMS:

“9204. Legislative findings and declarations regarding timely and complete payment of contractors for public works projects; claims process

(a) The Legislature finds and declares that it is in the best interests of the state and its citizens to ensure that all construction business performed on a public works project in the state that is complete and not in dispute is paid in full and in a timely manner.

(b) Notwithstanding any other law, including, but not limited to, Article 7.1 (commencing with Section 10240) of Chapter 1 of Part 2, Chapter 10 (commencing with Section 19100) of Part 2, and Article 1.5 (commencing with Section 20104) of Chapter 1 of Part 3, this section shall apply to any claim by a contractor in connection with a public works project.

(c) For purposes of this section:

(1) “Claim” means a separate demand by a contractor sent by registered mail or certified mail with return receipt requested, for one or more of the following:

(A) A time extension, including, without limitation, for relief from damages or penalties for delay assessed by a public entity under a contract for a public works project.

(B) Payment by the public entity of money or damages arising from work done by, or on behalf of, the contractor pursuant to the contract for a public works project and payment for which is not otherwise expressly provided or to which the claimant is not otherwise entitled.

(C) Payment of an amount that is disputed by the public entity.

(2) “Contractor” means any type of contractor within the meaning of Chapter 9 (commencing with Section 7000) of Division 3 of the Business and Professions Code who has entered into a direct contract with a public entity for a public works project.

(3) (A) “Public entity” means, without limitation, except as provided in subparagraph (B), a state agency, department, office, division, bureau, board, or commission, the California State University, the University of California, a city, including a charter city, county, including a charter county, city and county, including a charter city and county, district, special district, public authority, political subdivision, public corporation, or nonprofit transit corporation wholly owned by a public agency and formed to carry out the purposes of the public agency.

(B) “Public entity” shall not include the following:

(i) The Department of Water Resources as to any project under the jurisdiction of that department.

(ii) The Department of Transportation as to any project under the jurisdiction of that department.

(iii) The Department of Parks and Recreation as to any project under the jurisdiction of that department.

(iv) The Department of Corrections and Rehabilitation with respect to any project under its jurisdiction pursuant to Chapter 11 (commencing with Section 7000) of Title 7 of Part 3 of the Penal Code.

(v) The Military Department as to any project under the jurisdiction of that department.

(vi) The Department of General Services as to all other projects.

(vii) The High-Speed Rail Authority.

(4) “Public works project” means the erection, construction, alteration, repair, or improvement of any public structure, building, road, or other public improvement of any kind.

(5) “Subcontractor” means any type of contractor within the meaning of Chapter 9 (commencing with Section 7000) of Division 3 of the Business and Professions Code who either is in direct contract with a contractor or is a lower tier subcontractor.

(d) (1) (A) Upon receipt of a claim pursuant to this section, the public entity to which the claim applies shall conduct a reasonable review of the claim and, within a period not to exceed 45 days, shall provide the claimant a written statement identifying what portion of the claim is disputed and what portion is undisputed. Upon receipt of a claim, a public entity and a contractor may, by mutual agreement, extend the time period provided in this subdivision.

(B) The claimant shall furnish reasonable documentation to support the claim.

(C) If the public entity needs approval from its governing body to provide the claimant a written statement identifying the disputed portion and the undisputed portion of the claim, and the governing body does not meet within the 45 days or within the mutually agreed to extension of time following receipt of a claim sent by registered mail or certified mail, return receipt requested, the public entity shall have up to three days following the next duly publicly noticed meeting of the governing body after the 45-day period, or extension, expires to provide the claimant a written statement identifying the disputed portion and the undisputed portion.

(D) Any payment due on an undisputed portion of the claim shall be processed and made within 60 days after the public entity issues its written statement. If the public entity fails to issue a written statement, paragraph (3) shall apply.

(2) (A) If the claimant disputes the public entity’s written response, or if the public entity fails to respond to a claim issued pursuant to this section within the time prescribed, the claimant may demand in writing an informal conference to meet and confer for settlement of the issues in dispute. Upon receipt of a demand in writing sent by registered mail or certified mail, return receipt requested, the public entity shall schedule a meet and confer conference within 30 days for settlement of the dispute.

(B) Within 10 business days following the conclusion of the meet and confer conference, if the claim or any portion of the claim remains in dispute, the public entity shall provide the claimant a written statement identifying the portion of the claim that remains in dispute and the portion that is undisputed. Any payment due on an undisputed portion of the claim shall be processed and made within 60 days after the public entity issues its written statement. Any disputed portion of the claim, as identified by the contractor in writing, shall be submitted to nonbinding mediation, with the public entity and the claimant sharing the associated costs equally. The public entity and claimant shall mutually agree to a mediator within 10 business days after the disputed portion of the claim has been identified in writing. If the parties cannot agree upon a mediator, each party shall select a mediator and those mediators shall select a qualified neutral third party to mediate with regard to the disputed portion of the claim. Each party shall bear the fees and costs charged by its respective mediator in connection with the selection of the neutral mediator. If mediation is unsuccessful, the parts of the claim remaining in dispute shall be subject to applicable procedures outside this section.

(C) For purposes of this section, mediation includes any nonbinding process, including, but not limited to, neutral evaluation or a dispute review board, in which an independent third party or board assists the parties in dispute resolution through negotiation or by issuance of an evaluation. Any mediation utilized shall conform to the timeframes in this section.

(D) Unless otherwise agreed to by the public entity and the contractor in writing, the mediation conducted pursuant to this section shall excuse any further obligation under Section 20104.4 to mediate after litigation has been commenced.

(E) This section does not preclude a public entity from requiring arbitration of disputes under private arbitration or the Public Works Contract Arbitration Program, if mediation under this section does not resolve the parties' dispute.

(3) Failure by the public entity to respond to a claim from a contractor within the time periods described in this subdivision or to otherwise meet the time requirements of this section shall result in the claim being deemed rejected in its entirety. A claim that is denied by reason of the public entity's failure to have responded to a claim, or its failure to otherwise meet the time requirements of this section, shall not constitute an adverse finding with regard to the merits of the claim or the responsibility or qualifications of the claimant.

(4) Amounts not paid in a timely manner as required by this section shall bear interest at 7 percent per annum.

(5) If a subcontractor or a lower tier subcontractor lacks legal standing to assert a claim against a public entity because privity of contract does not exist, the contractor may present to the public entity a claim on behalf of a subcontractor or lower tier subcontractor. A subcontractor may request in writing, either on his or her own behalf or on behalf of a lower tier subcontractor, that the contractor present a claim for work which was performed by the subcontractor or by a lower tier subcontractor on behalf of the subcontractor. The subcontractor requesting that the claim be presented to the public entity shall furnish reasonable documentation to support the claim. Within 45 days of receipt of this written request, the contractor shall notify the subcontractor in writing as to whether the contractor presented the claim to the public entity and, if the original contractor did not present the claim, provide the subcontractor with a statement of the reasons for not having done so.

(e) The text of this section or a summary of it shall be set forth in the plans or specifications for any public works project that may give rise to a claim under this section.

(f) A waiver of the rights granted by this section is void and contrary to public policy, provided, however, that (1) upon receipt of a claim, the parties may mutually agree to waive, in writing, mediation and proceed directly to the commencement of a civil action or binding arbitration, as applicable; and (2) a public entity may prescribe reasonable change order, claim, and dispute resolution procedures and requirements in addition to the provisions of this section, so long as the contractual provisions do not conflict with or otherwise impair the timeframes and procedures set forth in this section.

(g) This section applies to contracts entered into on or after January 1, 2017.

(h) Nothing in this section shall impose liability upon a public entity that makes loans or grants available through a competitive application process, for the failure of an awardee to meet its contractual obligations.

(i) This section shall remain in effect only until January 1, 2020, and as of that date is repealed, unless a later enacted statute, that is enacted before January 1, 2020, deletes or extends that date.”

RESOLUTION OF CONSTRUCTION CLAIMS OF \$375,000 OR LESS

“20104. Application of article; provisions included in plans and specifications

(a) (1) This article applies to all public works claims of three hundred seventy-five thousand dollars (\$375,000) or less which arise between contractor and a local agency.

(2) This article shall not apply to any claims resulting from a contract between a contractor and a public agency when the public agency has elected to resolve any disputes pursuant to Article 7.1 (commencing with Section 10240) of Chapter 1 of Part 2.

(b) (1) "Public work" means “public works contract” as defined in Section 1101 but does not include any work or improvement contracted for by the State or the Regents of the University of California.

(2) "Claim" means a separate demand by the contractor for (A) a time extension, (B) payment of money or damages arising from work done by or on behalf of, the contractor pursuant to the contract for a public work and payment of which is not otherwise expressly provided for or the claimant is not otherwise entitled to, or (C) an amount the payment of which disputed by the local agency.

(c) The provisions of this article or a summary thereof shall be set forth in the plans or specifications for any work which may give rise to a claim under this article.

(d) This article applies only to contracts entered into on or after January 1, 1991.”

“20104.2. Claims; requirements; tort claims excluded

For any claim subject to this article, the following requirements apply:

(a) The claim shall be in writing and include the documents necessary to substantiate the claim. Claims must be filed on or before the date of final payment. Nothing in this subdivision is intended to extend the time limit or supersede notice requirements otherwise provided by contract for the filing of claims.

(b) (1) For claims of less than fifty thousand dollars (\$50,000), the local agency shall respond in writing to any written claim within 45 days of receipt of the claim, or may request, in writing, within 30 days of receipt of the claim, any additional documentation supporting the claim or relating to defenses to the claim the local agency may have against the claimant.

(2) If additional information is thereafter required, it shall be requested and provided pursuant to this subdivision, upon mutual agreement of the local agency and the claimant.

(3) The local agency's written response to the claim, as further documented, shall be submitted to the claimant within 15 days after receipt of the further documentation or within a period of time no greater than that taken by the claimant in producing the additional information, whichever is greater.

(c) (1) For claims of over fifty thousand dollars (\$50,000) and less than or equal to three hundred seventy-five thousand dollars (\$375,000), the local agency shall respond in writing to all written claims within 60 days of receipt of the claim, or may request, in writing, within 30 days of receipt of the claim, any additional documentation supporting the claim or relating to defenses to the claim the local agency may have against the claimant.

(2) If additional information is thereafter required, it shall be requested and provided pursuant to this subdivision, upon mutual agreement of the local agency and the claimant.

(3) The local agency's written response to the claim, as further documented, shall be submitted to the claimant within 30 days after receipt of the further documentation, or within a period of time no greater than that taken by the claimant in producing the additional information or requested documentation, whichever is greater.

(d) If the claimant disputes the local agency's written response, or the local agency fails to respond within the time prescribed, the claimant may so notify the local agency, in writing, either within 15 days of receipt of the local agency's response or within 15 days of the local agency's failure to respond within the time prescribed, respectively, and demand an informal conference to meet and confer for settlement of the issues in dispute. Upon a demand, the local agency shall schedule a meet and confer conference within 30 days for settlement of the dispute.

(e) Following the meet and confer conference the claim or any portion remains in dispute, the claimant may file a claim as provided in Chapter 1 (commencing with Section 900) and Chapter 2 (commencing with Section 910) of Part 3 of Division 3.6 of Title 1 of the Government Code. For purposes of those provisions, the running of the period of time within which a claim must be filed shall be tolled from the time the claimant submits his or her written claim pursuant to subdivision (a) until the time that claim is denied as a result of the meet and confer process, including any period of time utilized by the meet and confer process.

(f) This article does not apply to tort claims and nothing in this article is intended nor shall be construed to change the time periods for filing tort claims or actions specified by Chapter 1 (commencing with Section 900) and Chapter 2 (commencing with Section 910) of Part 3 of Division 3.6 of Title 1 of the Government Code.”

“20104.4. Civil action procedures; mediation and arbitration; trial de novo; witnesses

The following procedures are established for all civil actions filed to resolve claims subject to this article:

(a) Within 60 days, but no earlier than 30 days, following the filing or responsive pleadings, the court shall submit the matter to nonbinding mediation unless waived by mutual stipulation of both parties. The mediation process shall provide for the selection within 15 days by both parties of a disinterested third person as mediator, shall be commenced within 30 days of the submittal, and shall be concluded within 15 days from the commencement of the mediation unless a time requirement is extended upon a good cause showing to the court or by stipulation of both parties. If the parties fail to select a mediator within the 15-day period, any party may petition the court to appoint the mediator.

(b)(1) If the matter remains in dispute, the case shall be submitted to judicial arbitration pursuant to Chapter 2.5 (commencing with Section 1141.10) of Title 3 of Part 3 of the Code of Civil Procedure, notwithstanding Section 1141.11 of that code. The Civil Discovery Act (Title 4 (commencing with Section 2016.010), of the Code of Civil Procedure) shall apply to any proceeding brought under this subdivision consistent with the rules pertaining to judicial arbitration.

(2) Notwithstanding any other provision of law, upon stipulation of the parties, arbitrators appointed for purposes of this article shall be experienced in construction law, and, upon stipulation of the parties, mediators and arbitrators shall be paid necessary and reasonable hourly rates of pay not to exceed their customary rate, and such fees and expenses shall be paid equally by the parties, except in the case of arbitration where the arbitrator, for good cause, determines a different division. In no event shall these fees or expenses be paid by state or county funds.

(3) In addition to Chapter 2.5 (commencing with Section 1141.10) of Title 3 of Part 3 of the Code of Civil Procedure, any party who after receiving an arbitration award requests a trial de novo but does not obtain a more favorable judgment shall, in addition to payment of costs and fees under that chapter, pay the attorney's fees of the other party arising out of trial de novo.

(c) The court may, upon request by any party, order any witnesses to participate in the mediation or arbitration process.”

“20104.6. Payment on undisputed portion of claim; interest on arbitration award or judgment

(a) No local agency shall fail to pay money as to any portion of a claim which is undisputed except as otherwise provided in the contract.

(b) In any suit filed under Section 20104.4, the local agency shall pay interest at the legal rate on any arbitration award or judgment. The interest shall begin to accrue on the date the suit is filed in a court of law.”

T. WORKING HOUR RESTRICTIONS: Eight hours’ labor is a legal day’s work. Any workers time of service is restricted to eight hours during any calendar day and forty hours during any calendar week, unless overtime compensation is paid at not less than one and one-half times the basic rate of pay. The Contractor or Subcontractor shall, as a penalty to the City forfeit twenty-five dollars (\$25) for each worker employed in the execution of the contract by the respective Contractor or subcontractor for each calendar day during which the worker is required or permitted to work more than eight hours in any one calendar day and forty hours in any one calendar week in violation of the law.

U. EXAMINATION AND AUDIT: All documents and records that relate in any way to this Agreement shall be maintained for a period of three years after the final payment under this Agreement. These records shall be subject to the examination and audit by the City and by the State Auditor, at the request of the City or as part of any audit of the City, for a period of three years after final payment under the Agreement.

V. DELAYS AND EXTENSIONS OF TIME

6-6.4 Written Notice and Report. The first sentence of subsection 6-6.4 is hereby deleted and replaced with the following:

“If the Contractor desires payment for a delay as specified in Subsection 6-6.3 of the Standard Specifications, it shall notify the Engineer in writing within 3 days of the beginning of the delay. If the Contractor desires an extension of time as specified in Subsection 6-6.2 of the Standard Specifications, it shall notify the Engineer in writing within 3 days of the beginning of the delay. Such notice shall specify the nature of the delay, cause, and the conditions that set the beginning time for the delay.”

W. PROTECTION AND RESTORATION OF EXISTING IMPROVEMENTS

The second paragraph of Subsection 7-9 of the Standard Specifications is hereby deleted and replaced with the following:

“The Contractor shall relocate, repair, replace, or reestablish all existing improvements within the project limits which are not designated for removal (e.g., curbs, sidewalks, driveways, fences, walls, sprinkler systems, signs, utility installations, pavements, structures, etc.) which are damaged or removed as a result of his operations or as required by the Plans and Specifications.

Where existing traffic striping, pavement markings, and curb markings are damaged or their reflectivity reduced by the Contractor's operations, such striping or markings shall also be considered as existing improvements and the Contractor shall repaint or replace such improvements.

Relocations, repairs, replacements, or reestablishments shall be at least equal to the existing improvements and shall match such improvements in finish and dimensions unless otherwise specified.”

The last paragraph of Subsection 7-9 of the Standard Specifications is hereby deleted and replaced with the following:

“All costs to the Contractor for protecting, removing, restoring, relocating, repairing, replacing, or reestablishing existing improvements shall be included in the unit cost for the various items of work and no additional compensation will be allowed therefor.”

2. PUBLIC CONVENIENCE AND SAFETY

A. GENERAL: In addition to the requirements specified in Subsections 7-10 of the Standard Specifications, traffic control shall conform to the provisions of the latest edition of the State of California, Department of Transportation, "Manual of Traffic Controls."

The Contractor shall give one week advance notice prior to the start of construction to all residences and businesses facing or siding on the construction area. Said notice shall be in writing on the Contractor's letterhead and shall explain in concise terms the extent and nature of the Work, the anticipated schedule, and office and emergency telephone numbers where the Contractor's representative can be reached.

Should the Contractor appear to be neglectful or negligent in furnishing warning and protective measures, the Engineer may direct attention to the existence of a hazard and the necessary warning and protective measures shall be furnished and installed immediately by the Contractor at his expense.

Should the Engineer point out the inadequacy of warning and protective measures, such action on the part of the Engineer shall not relieve the Contractor from responsibility for public safety or abrogate his obligation to furnish and pay for these devices.

If the Contractor cannot be contacted or if attention is directed to the existence of a hazard and the Contractor fails to provide the necessary safety devices, said devices will be placed, or caused to be placed, by the City. The cost of placement to these devices shall be the sole responsibility of the Contractor and shall be paid for at the rate of \$50 per call-out plus \$25 per traffic control device for each 24 hours, or fraction thereof, that the device is required. Said costs shall be deducted from the total contract price for the work.

Prior to beginning any construction, the Contractor shall furnish the Engineer with local emergency phone numbers where he or a representative may be contacted during non-working hours or days for the purpose of replacing or providing additional warning or safety devices as directed by the Engineer.

B. UTILITIES: It is anticipated that the existing utilities will not interfere with the Contractor's construction operations. However, the Contractor shall exercise due care to ensure that the utility facilities are not damaged during his operations, and must notify utilities and obtain an identification number before excavation or be subject to liability for damages to subsurface installations. When in doubt, the Contractor shall contact the utility concerned before proceeding further.

Upon completion of the project, the Contractor shall be responsible to remove all painted utility markings, whether done by him or the respective utility owners on behalf of the contractor for this project work, from the surfaces of sidewalks, driveway approaches, curbs and gutters using the removal method acceptable to the Engineer. Any damage to sidewalks, driveway approaches, curbs and gutters due to the Contractor's removal operation shall be repaired at the Contractor's expense and to the satisfaction of the Engineer. Payment for removing utility markings shall be included in other items of work, and no additional compensation will be allowed therefore.

C. LOCATION: The location and existence of any underground utility or substructure, if shown on Plans, was obtained from a search of available records. No guarantee is made or implied that the information is complete or accurate. It shall be the Contractor's responsibility alone to determine the exact location of underground utilities or substructures of every nature and to protect them from damage. The Contractor shall excavate and expose all high-risk underground facilities.

The Contractor shall notify the owners of all utilities and substructures as set forth in the General Provisions.

D. RELOCATION: The second sentence of the last paragraph of Subsection 5-4 of the Standard Specifications is hereby deleted and replaced with the following:

When not otherwise required by the Plans and Specifications and when directed by the Engineer, the Contractor shall arrange for the relocation of service connections, as necessary, between the meter and property line, or between the meter and limits of construction.

The Contractor shall be compensated for the costs of locating and repairing, removing and relocating utility facilities, provided that any damage is not due to the failure of the Contractor or subcontractor to exercise reasonable care and the utility facilities were not indicated in the plans and specifications with reasonable accuracy. The Contractor shall not be assessed liquidated damages for delay in completion of the project, when such delay was caused by the failure of the City or the owner of the utility to provide for removal or relocation of such utility facilities.

E. DELAYS: The second paragraph of Subsection 5-5 is hereby deleted and replaced with the following two paragraphs:

The Contractor will not be entitled to damages or additional payment for delays attributable to utility relocations or alterations if correctly located, noted and completed in accordance with Subsection 5-1. The Contractor shall ascertain further detailed information to coordinate his work to this effect.

All notification of utility companies shall be by the Engineer based on Contractor's request as submitted to the Engineer at least 72 hours in advance of the needed work. Any costs for delay of the Contractor or utility companies in this regard shall be assigned to the Contractor, if these costs are a result of the Contractor's request being untimely in any respect, except for the utility company not responding at their agreed time.

F. AIR POLLUTION CONTROL

Section 7-8.2, "Air Pollution", of the Standard Specifications is supplemented by the following:

“The Contractor shall comply with all air pollution control rules, regulations, ordinances and statutes which apply to any work performed pursuant to the contract including any air pollution control, rules, regulations, ordinances and statutes specified in Section 11017 of the Government Code.

In the absence of any applicable air pollution control rules, regulations, ordinances or statutes governing solvents, all solvents, including but not limited to the solvent portions of paints, thinners, curing compounds, and liquid asphalt used on the project shall comply with the applicable material requirements of the County Air Pollution Control District. All containers of paint, thinner, curing compound or liquid asphalt shall be labeled to indicate that the contents fully comply with said requirements.”

G. WATER POLLUTION: The Contractor shall comply with the requirements of Subsection 7-8.6 of the Standard Specifications and shall conduct his operations so as to prevent portland cement, mud, silt or other materials from entering the surface drainage structures of the adjoining street and any underground storm drainage system.

Full compensation for prevention of water pollution and all required control work for preservation, clean-up and restoration of damaged property shall be considered as included in the unit cost for the various contract items of work, and no additional compensation will be allowed therefor.

H. PROJECT APPEARANCE: The Contractor shall maintain a neat appearance to the work.

Full compensation for conforming to the provisions of this section not otherwise provided for shall be considered as included in unit cost for the various contract items of work involved and no additional compensation will be allowed therefor.

I. WORK HOURS: The Contractor's working hours shall be limited to the hours between 7:00 a.m. and 5:00 p.m., excluding recognized holidays. Deviation from normal working hours will not be allowed without prior consent of the City Engineer.

In the event work is allowed by the Engineer outside of the normal working hours, at the request of and for the benefit of the Contractor, inspection service fees may be levied against the Contractor at a rate of \$50.00 per hour, including travel time where applicable. The above charge may also be levied if inspection services are deemed necessary by the Engineer as a matter of public safety or to otherwise insure the quality of the work.

J. CONSTRUCTION YARD: It shall be the Contractor's responsibility to locate any storage sites for materials and equipment needed and such sites must be approved in advance by the Engineer and must be free of objectionable material. The Contractor must submit to the Engineer for approval any and all agreement(s) between the Contractor and the property owner(s) of said storage site(s) and/or construction site(s) for approval prior to the start of construction. Said agreement(s) must provide for the restoration of the site(s) by the Contractor prior to the filing of "Notice of Completion" by the Engineer. Full compensation shall be considered as included in unit cost for the various contract items of work involved and no additional compensation will be allowed therefor.

No equipment or material used for staging shall be allowed to be stored on any City streets during non-work time. All stage equipment and/or material shall be stored offsite and if such location is used, it shall be submitted in writing and approved by the City Engineer. All costs associated with such staging and location shall be included in other bid items of work and no additional compensation will be allowed thereof.

K. SANITARY CONVENIENCE: Necessary sanitary facilities for the use of the workmen performing the work, properly secluded from public observation and in compliance with health ordinances and laws, shall be constructed and maintained by Contractor, in a manner approved by the Engineer, and the use of such facilities shall be strictly enforced by the Contractor.

L. INSPECTION: The Engineer, or his authorized agent, shall at all times have access to work during construction and shall be furnished, to the extent possible, complete information and all documentation to ascertain full knowledge regarding the progress, workmanship and character of materials used and employed in the work. Whenever required, the Contractor shall furnish to the City for test, and free of charge, samples of any one of the materials proposed to be used in the work. Said samples shall be delivered by the Contractor at the place within the City designated by the Engineer. Rejected material must be immediately removed from the work by the Contractor and shall not again be brought back to the site of the improvement.

The Contractor shall notify the Engineer or his authorized agent forty-eight (48) hours in advance when he will require inspection for either material or work to be done.

The inspection of the work shall not relieve the Contractor of any of his obligations to fulfill the contract as prescribed. Defective work shall be made good, and unsuitable materials may be rejected, notwithstanding the fact that such defective work and unsuitable materials have been previously overlooked by the Engineer or his authorized agent and accepted or estimated for payment.

M. RESPONSIBILITY OF THE CITY: The City shall not be held responsible for the care or protection of any material or parts of the work prior to final acceptance, except as expressly provided for in these Contract Documents.

N. RECYCLING OF MATERIALS: Contractor's Obligation. Recycling of asphalt concrete, portland cement concrete, aggregate base, and green waste (trees and shrubs) is required. The Contractor is required to recycle at least 65% of all recyclable materials. All recycled materials shall be weighed on a certified weigh scale with weight tickets showing project name. **RECORDS OF DISPOSAL, INCLUDING WEIGHT OF MATERIALS, SHALL BE SUBMITTED TO THE CITY THE AGENCY ON A MONTHLY BASIS.**

Prior to commencing work, the Contractor shall complete the "Construction and Demolition Waste Reduction and Recycling Plan" form and submit it to the Public Works Department for review and approval. The Contractor will be expected to follow the approved Plan and document results during construction. At the completion of activities, the Contractor shall submit the "Construction and Demolition Waste Reduction and Recycling Report" form to the Public Works Department for review and approval of compliance with the Plans. The above-referenced forms are provided in Appendix 2.

The Contractor is obligated, under this contract, to recycle the waste material through an approved recycling plant. **In the event the Contractor fails to comply with the C&D requirements (at least 65%), three percent (3%) of the approved contract amount will be forfeited to the City by Contractor as a penalty.**

Payment for Recycling of Materials shall be included in the unit cost for the various contract items of work and no additional compensation will be allowed therefor.

O. TRAFFIC AND ACCESS: *The Contractor shall notify the occupants of all affected properties at least 48 hours prior to any temporary obstruction of access. Vehicular access to property line shall be maintained, except as required for construction for a reasonable period of time. No overnight closure of any driveway will be allowed, except as permitted by the Engineer. Temporary ramps for driveways shall be provided and maintained by the end of each working day and during the weekends. Temporary driveway ramps shall be constructed with crushed miscellaneous base as directed by the Engineer.*

Contractor shall maintain vehicular, bicycle, and pedestrian traffic access through the project area at all times. A minimum of one 12-foot wide traffic lane and a minimum of one 4-foot wide all-weather paved pedestrian walkway shall be provided at all times, except as permitted by the Engineer. During times when less than 2 lanes of traffic are provided, contractor shall provide traffic control for the entire duration there is less than 2 lanes. The traffic lanes shall be maintained on all-weather pavement and shall remain unobstructed.

P. STREET CLOSURES, DETOURS, BARRICADES, PARKING: Street closures will not be allowed, except as specifically permitted by the Engineer.

The Contractor shall prepare any traffic control or detour plans that may be required as directed by the Engineer.

Lane transitions shall conform to the Caltrans Traffic Manual, Section 5-08.4, "Transition Area."

Temporary traffic channelization shall be accomplished with delineators. Temporary striping will not be allowed unless specifically permitted by the Engineer. The Contractor shall prepare any plans that may be required for temporary striping to the satisfaction of the Engineer. In no event will temporary striping be allowed on finished pavement surfaces which are to remain.

The Contractor shall schedule an employee to police the temporary delineators and barricades within the travel way during weekday, nonworking hours and over Saturdays, Sundays, and holidays. Any corrective work required to be done by City forces shall be back charged to the Contractor based on the actual costs, plus City overhead and withheld from the final payment.

As specified in the General Provisions, the schedule shall be submitted to the Engineer for approval prior to commencing work. This schedule shall allow affected people ample "on-street" parking within a reasonable distance from their homes and businesses. Requests for changes in the schedule shall be made in accordance with the General Provisions.

Temporary "No Parking" signs shall be posted at least 24 hours, but no more than 48 hours, in advance of the work. The signs shall be placed no more than 250 feet apart on each side of the street and at shorter intervals if conditions warrant. Signs shall be posted only for the areas necessary to accomplish the work. The Contractor shall provide the signs and will be responsible for adding the dates and hours of closure to the signs, removal of the signs, and furnishing and placing of barricades, if necessary, for posting of signs. All signs shall be removed within 48 hours after the effective date.

Payment for STREET CLOSURES, DETOURS, BARRICADES, PARKING shall be considered as included in the unit cost for bid item: "Traffic Control" no additional compensation will be allowed therefor.

TECHNICAL PROVISIONS

CITY OF LAWNSDALE

FY 2023-24 ANNUAL STRIPING PROJECT

A. SCOPE OF WORK

The work consists of furnishing all materials, equipment, tools, labor, and incidentals required to complete the improvements shown on the Plans, Specifications and Contract Documents. The work performed under this contract is summarized in the Notice Inviting Sealed Bids. The Scope of Work includes, but is not limited to, each bid item listed in the Contractor's Bid Proposal, as shown on the plans as covered in the Standard Specifications, and as described in the corresponding items on the following pages.

The work in general, to be performed pursuant to these specifications, consists of removing and installing thermoplastic crosswalks; refer to the Plans and Specifications for further information.

B. TIME OF COMPLETION

The Contract Time of Completion is specified in the Bid Form.

C. COOPERATION.

The Contractor shall cooperate with utility personnel and its contractors and their personnel and provide access to the work site. Notification, scheduling and coordination of construction with the respective utility are the responsibility of the Contractor. The following list of names and telephone numbers is intended for the convenience of the Contractor and is not guaranteed to be complete or correct:

Project Specific Utility Notifications and Contacts:

<i>Company</i>	<i>Contact</i>
City of Lawndale	Nabi Siddiqi Assistant Engineer (310)973-3261
Golden State Water Company	Joe Salcido, Ops Sup (310) 660-0320 ext 101 (805) 297-0971
Southern California Edison	General Planning (310)783-9389

AT&T	AT&T Representative (800)222-0300
Southern California Gas	So. California Gas Rep. (800)427-2200
Verizon	Maintenance (888)875-4144
Time Warner Cable	Stan Walker (424)212-6994
LA Co. Dept of Public Works Road Dept.	George Ellis (626)458-1700 ext. 1629
LA Co. Dept of Public Works Sewer Maint.	Nicholas Agbotbu (626)300-3382
LA Co. Dept of Public Works	Request for Service (626)458-4357
West Basin Municipal Water District	Wyatt Woan (310)660-6203
County Sanitation District of Los Angeles	Mike Sullivan (562)908-4288 ext.2501

D. EMERGENCY INFORMATION

The names, addresses, and telephone numbers of the Contractor and Subcontractors, or their representatives, shall be filed with the Public Works Department, Police and Fire Department prior to beginning work.

E. ENVIRONMENTAL MITIGATION

The Contractor shall comply with the following environmental mitigations:

All storm drains within and immediately adjacent to the project limits are to be protected from pollutants through the use of BMP's as directed by the Public Works Department. BMP's will include but are not limited to placement of sandbags or other water containment devices and wet vacuuming of concrete residue during saw cutting and pressure washing operations. Washing down of sediment, concrete residue or any other debris to the storm drain is strictly prohibited

by City Ordinance and State regulation of storm water quality. The BMP's shall be furnished and installed by the Contractor, and no additional compensation will be allowed therefore.

F. DESCRIPTION OF BID ITEMS

The unit prices to be paid for the items listed in the Contractor's Proposal as defined herein shall be considered full compensation for furnishing all labor, materials, tools and equipment, and disposal materials, and doing all work involved in furnishing and installing the materials complete and in place, in accordance with the details shown on the Plans, as specified herein, and as directed by the City Public Works Department.

All incidental work which is neither shown on the Plans nor otherwise specified, and which is necessary to complete the construction of improvements as shown on the Plans and as specified herein, shall be furnished and installed as though such work were shown on the Plans or specified herein, and no additional compensation will be allowed therefore.

G. APPLICABLE STANDARD SPECIFICATIONS

The work to be done under this Contract requires the completion of all work in accordance with the General Specifications and the Technical Provisions herein, and the following Standard Specifications and Standard Drawings, as modified herein. In the case of conflict between the Standard Specifications and Standard Drawings and the Technical Provisions and Construction Drawings, the Technical Provisions shall take precedence over all of the following referenced Standard Specifications and Standard Drawings, in all areas. Said referenced Standard Specifications and Standard Drawings shall take precedence in the following order:

1. "Los Angeles County Department of Public Works Standards", latest edition. Said "Standard Drawings" are incorporated herein by this reference.
2. State of California, Department of Transportation (CALTRANS), Standard Specifications and Standard Plans, 2018 (Revised) editions. Said "State Standard Specifications" and "State Standard Plans" are incorporated herein by this reference.
3. "State of California Manual on Uniform Traffic Control Devices" (California MUTCD), latest edition, is incorporated herein by this reference.
4. "Standard Specifications for Public Works Construction", (Green Book), 2018 edition including all revisions, addendums and supplements, for civil work, curb ramps, sidewalk, and curb & gutter. Said "Standard Specifications" are incorporated herein by this reference. Copies may be purchased from Building News, Inc. 3055 Overland Avenue, Los Angeles, California 90034.

1. PRIOR TO CONSTRUCTION

1. Contractor shall obtain encroachments and excavation permit from the City.
2. Contractor shall notify the Police and Fire Departments giving the expected starting date, the name and telephone number of a responsible person that is to be contacted, at any hour in the event of a condition requiring immediate correction. Emergency vehicles shall be permitted to pass through the work area, without delay, at all times.
3. Contractor shall notify businesses as required in the Special and Technical Provisions. The notice shall include but not limited to:
 - a. The Time and Date of Working Days.
 - b. A copy of the approved construction schedule (must be approved by the City).
 - c. Completion Date.
 - d. Distribution of Construction Notification Letter (must be approved by the City).

Section 2 – SCOPE AND CONTROL OF THE WORK

2-1 AWARD AND EXECUTION OF CONTRACT. Replace the entire subsection with the following:

Within ten (10) working days after the date of the CITY'S award of contract, the Contractor shall execute and return all Contract Documents required by the CITY. The CITY reserves the right to terminate the award if the above requirement is not met. Such termination will result in the forfeiture of the Proposal Guaranty.

The Contract shall not be considered binding upon the CITY until executed by the authorized CITY officials.

2-3 SUBCONTRACTS

2-3.2 SELF PERFORMANCE. Replace the second sentence with the following:

There are no specialty items.

2-4 CONTRACT BONDS. Revise the second sentence of the fourth paragraph to read as follows:

The "Performance Bond" shall remain in effect for one year following the date specified in the Notice of Completion or, if no Notice of Completion is recorded, for one year following the date of final acceptance by the Engineer.

2-5. PLANS AND SPECIFICATIONS.

2-5.1 General. Add the following sentence to the first paragraph to read as follows:

All final locations determined in the field, and any deviations from the Plans and Specifications, shall be marked in red on this control set to show as-built conditions. Upon completion of the Work, the Contractor shall submit the control set to the Engineer for approval. Final payment will not be made until this requirement is met.

Add the following subsections:

2-5.1.1 Plans. Included as part of the Contract Documents are the following, which show the location, character, dimensions or details of the Work:

1) Project Plans

The existing utility information and data provided with the Contract Documents are based on existing plans and documents. The plans and data are provided for information only. The Owner does not guarantee their accuracy and correctness. If the Bidder in preparing the Bid Proposal uses this information, the Bidder assumes all risks resulting from conditions differing from the information shown. The Bidder, in consideration for the information being provided, hereby releases the Owner and Consulting Engineer from any responsibility of obligation as to the accuracy of such information or for any additional compensation for work performed due to assumptions based on the use of such information.

2) Standard Plans

- a. Standard Plans for Public Works Construction, 2012 edition, promulgated by Public Works Standards, Inc.
- b. Standard Plans of the State of California Department of Transportation (Caltrans), 2018 edition

Applicable Standard Plans and information for this project are included in the Appendices of these Specifications.

2-5.1.2 Specifications. The Work shall be performed or executed in accordance with these Special Provisions and the following:

1) Standard Specifications for Public Works Construction, 2012 Edition and supplements thereto, hereinafter referred to as the Standard Specifications, as written and promulgated by Public Works Standards, Inc. The Standard Specifications are published by BNi Building News, Inc., 1612 South Clementine Street, Anaheim, CA 92802, Phone: (800) 873-6397.

2) Sections 56, 81, 84, and 85 of the State of California Department of Transportation (Caltrans) Standard Specifications, 2010 edition.

2-5.2 Precedence of Contract Documents. Replace the entire subsection with the following:

If there is a conflict between any of the Contract Documents, the document highest in precedence shall control. The order of precedence shall be as follows:

- 1) Permits issued by other agencies.
- 2) Change Orders (including Plans and Specifications attached thereto).
- 3) Public Works Agreement
- 4) Addenda
- 5) Special and General Provisions
- 6) Plans
- 7) City Standard Plans
- 8) Other Standard Plans
- 9) Standard Specifications for Public Works Construction
- 10) Reference Specifications

With reference to the Plans/Drawings, the order of precedence is as follows:

- 1) Change Order plans govern over Addenda and Contract plans
- 2) Addenda plans govern over Contract plans
- 3) Contract plans govern over standard plans
- 4) Detail plans govern over general plans
- 5) Figures govern over scaled dimensions

Within the Specifications, the order of precedence is as follows:

- 1) Change Orders
- 2) Permits from other agencies/Supplemental Agreements
- 3) Special Provisions
- 4) Instruction to Bidders
- 5) Referenced Standard Plans
- 6) Referenced Standard Specifications

If the Contractor, in the course of the Work, becomes aware of any claimed errors or omissions in the Contract Documents or in the CITY's fieldwork, the Contractor shall immediately inform the Engineer. The Engineer shall promptly review the matter, and if the Engineer finds an error or omission has been made the Engineer shall determine the corrective actions and advise the Contractor accordingly. If the corrective work associated with an error or omission increases or decreases the amount of work called for in the Contract, the CITY shall issue an appropriate Change Order in accordance with 3-3. After discovery of an error or omission by the Contractor, any related work performed by the Contractor shall be done at the Contractor's risk unless authorized by the Engineer.

2-5.3 Submittals

2-5.3.4 Supporting Information. Replace the second paragraph with the following:

Submittals are required for the following:

- 1) Certificate of Compliance
- 2) Emergency Contact List
- 3) Advance Notice of Construction
- 4) Construction schedule per Section 6-1
- 5) Thermoplastic for Crosswalk Striping
- 6) Paint for Traffic Striping and Crosswalk Striping
- 7) Pavement Markers

In addition to the above, submittals may be required for any product, manufactured item, or system not specifically listed above.

2-5.4 Examination of Documents. The bidder shall carefully examine the entire site of the work, including but not restricted to the conditions and encumbrances related thereto, the Plans and Specifications, and the proposal and contract forms therefore. The submission of a bid shall be conclusive evidence that the bidder has investigated and is satisfied as to the conditions to be encountered, as to the character, quality, and scope of the work to be performed, the quantities of material to be furnished and as to the requirements of the proposal, Plans, Specifications, and the contract.

2-6 WORK TO BE DONE. Add the following:

The Work generally consists of installation of traffic striping and pavement markings over existing striping, removal and installation of traffic markers, and installation of all turn pocket line extension and all directional lane lines through intersections along arterial corridors and residential zones at locations shown on the Project Location Map to the limits determined by the Engineer; and installation of crosswalk striping as described in Part 6: Description of Bid Items.

2-9 SURVEYING.

2-9.1 Permanent Survey Markers. Replace the entire Subsection 2-9.1 with the following:

The Contractor shall not disturb survey monuments, lot stakes (tagged), centerline ties, or benchmarks without notifying the Engineer. The Contractor shall be responsible to have a CA Registered Land Surveyor document all surveying monuments, lot stakes (tagged), centerline ties, and bench marks that may be disturbed during construction. In the event that identification numbers on survey monuments are illegible, it shall be the responsibility of the Contractor to obtain all information necessary to restore the monuments in their correct location. The Contractor or its Surveyor shall file a Corner Record Form at the Los Angeles County Surveyor referencing survey monuments subject to disturbance prior to the start of construction and also prior to the completion of construction, including a location for reestablishment of disturbed monuments. Copies of the records shall be provided to the City. Final payment will not be made until the aforementioned documentation is provided to the CITY.

All surveying shall be performed by a CA Registered Licensed Land Surveyor or a Registered Civil Engineer authorized to practice land surveying within the state. All monuments and centerline ties shall be tied out and reset in accordance with Section 8771 (Land Surveyors Act) of the Business and Professions Code of the State of California.

2-9.2 Survey Service. Replace the first two paragraphs with the following:

All construction surveying necessary to complete the Work shown on the Plans and provided in these Contract Documents shall be accomplished by or under the direction of a Registered Land Surveyor or Registered Civil Engineer authorized to practice land surveying in the State of California, retained and/or provided by the Contractor. The CITY reserves the right to direct additional construction survey work to be performed at no additional cost when the City determines additional construction survey is required to adequately construct the Work.

The Contractor shall notify the Engineer in writing at least 2 working days prior to the actual survey. The Contractor shall provide any required traffic control necessary for construction surveying. Permission to close more than one travel lane at a time for any survey service activity must be approved by the Engineer. Prior to disturbing survey monuments, the Contractor shall notify the Engineer in accordance with Section 2-9.1.

Stakes shall be set and stationed by the Contractor for curbs, curbs and gutters, sidewalks, access ramps, cross gutters, driveways, headers, storm drains, sewers, water lines, spandrels, catch basins, rough grade, and other items as necessary. If there are no elevations shown on the Plans or provided in the Specifications associated with any proposed improvement that requires stakes, the Contractor is directed to immediately notify the Engineer in writing in the form of a RFI. The City will respond to each RFI in a timely manner based on the completeness and complexity of the RFI. The Contractor is solely responsible for any time delays and/or any costs when it does not submit an RFI in a timely manner. A corresponding cut or fill to finished grade (or flow line) shall be indicated on a grade sheet. A copy of each grade sheet shall be furnished to the Engineer no more than 2 working days following the setting of stakes and prior to constructing a proposed improvement associated with the stakes. If any construction survey stakes are lost or disturbed and need to be replaced, such replacement shall be by the Contractor at its expense. If any improvement is constructed: incorrectly as determined by the Engineer; and/or without survey stakes provided to the Engineer; and/or via unilaterally by the Contractor, the Engineer reserves the right to direct the Contractor to remove and replace the improvement. All costs and time delays related to removal and replacement will be the sole responsibility of the Contractor.

Construction stakes shall consist of the following:

- a. Offset line and grade stakes for gravity sewer at 50-foot intervals with grade sheets indicating cut to the pipe invert.
- b. One set of control stakes for manholes and jacking pits.
- c. One set of paving stakes.
- d. Pipe heading checks for line and grade at each manhole.
- e. Line and grade of new curb and gutter
- f. Line and grade of existing features shown on the plan to be replaced in kind sufficient for their construction

The Contractor shall submit to the City within 2 days after completion of each respective survey, setting of each stake and heading check a copy of the survey notes and calculations certified by the licensed Land Surveyor for the following:

- a. Level and horizontal control circuit for survey control.
- b. Grade sheets for pipeline stakes.
- c. Pipe heading checks. Add the following subsection:

2-9.5 Payment Payment for surveying is included in the price bid for appurtenant bid items. No separate payment will be made for surveying services.

2-10 AUTHORITY OF THE BOARD AND THE ENGINEER. Add the following:

Failure of the Contractor to comply with the requirements of the Contract Documents, or to follow the directions of the Engineer, and/or to immediately remedy such noncompliance or to follow directions, may, upon notice from the Engineer, result in the suspension of the Contract monthly progress payments. Any monthly progress payments so suspended may remain in suspension until the Contractor is in compliance with the Contract Documents and the directions of the Engineer, as determined by the Engineer.

2-11 INSPECTION. Replace the entire subsection with the following:

The Work is subject to inspection and approval by the Engineer. The Contractor shall notify the Engineer a minimum of 48 hours in advance of the required inspection. For work already scheduled for inspection or is undergoing continuous inspection, the Contractor shall notify the Engineer of any cancellation by 3:00PM of the working day prior to the scheduled work. A penalty equivalent to the minimum half-day rate for the inspector shall be deducted from payments due to the Contractor for failure to provide advance notification.

The Engineer will make, or have made, such inspections and tests as he deems necessary to see that the Work is in conformance with the Contract Documents. In the event such inspections or tests reveal noncompliance with the Contract Documents, the Contractor shall bear the cost of such corrective measures as deemed necessary by the Engineer, as well as the cost of subsequent re-inspection and re-testing.

Work done in the absence of inspection by the Engineer may be required to be removed and replaced under the inspection of the Engineer, and the entire cost of removal and replacement, including the cost of all materials which may be furnished by the CITY and used in the work thus removed, shall be borne by the Contractor, regardless of whether the work removed is found to be defective or not. Work covered without the approval of the Engineer shall, if so directed by the Engineer, be uncovered to the extent required by the Engineer, and the Contractor shall similarly bear the entire cost of performing all the work and furnishing all the materials necessary for the removal of the covering and its subsequent replacement, including all costs for additional inspection.

The Engineer and any authorized representatives shall at all times have access to the Work during its construction at shops and yards as well as the Work site. The Contractor shall provide every reasonable facility for ascertaining that the materials and workmanship are in accordance with the Contract Documents.

Inspection of the Work shall not relieve the Contractor of the obligation to fulfill all conditions of the Contract.

Add the following subsections:

2-11.1 Special Inspection Fees. If the Contractor elects to work under this Contract more than 8 hours/day or more than 40 hours/week, Saturday, Sunday, or CITY holidays, the Contractor shall arrange with the Engineer for the required inspection service and pay the Special Inspection Fees which will be charged at the following rates:

Mondays through Fridays - \$150.00 per hour
Saturdays, Sundays, Holidays - \$1,200.00 per day

Fees may be deducted from payments due to the Contractor at the discretion of the Engineer.

If the Contractor works under this contract at times other than within the allowed working hours without permission from or prior arrangement with the Engineer, the Contractor will be charged a lump sum amount of \$500.00 for each occurrence, in addition to the above fees. The amount will be deducted from a Progress Payment.

2-11.2 General Requirements. The Contractor shall comply with the following requirements:

- 1) No excavation or open trench may be backfilled without first securing Health Department approval. If any piping, reclaimed or potable, is installed prior to plan check approval and/or inspection, all or any portion of the system may be required to be exposed and corrected as necessary.
- 2) Unused or abandoned potable water lines are to be severed as close to water mains as practical, capped, and a 10-foot section of abandoned line removed and cemented under Health Department supervision.
- 3) A dye or pressure test must be utilized to confirm the physical separation of the reclaimed and potable water system. Said testing shall be performed in conjunction with the Water Department and the Health Department and conducted before the introduction of reclaimed water.

2-11.3 Inspections During Construction. During the construction, the Contractor shall make the Work site available for periodic inspections by the regulatory agencies. These agencies may include: Los Angeles County Department of Health Services, Los Angeles Regional Water Quality Control Board, the State Water Resources Control Board, Division of Drinking Water and CITY Water Department.

2-11.4 Material Inspection/Testing and other City Expenses.

(a) If a City subcontractor hired to perform material inspection and/or testing is required to work additional time to perform inspection and testing as a result of an action or delay caused by the Contractor, except for specific work allowed by the Engineer, the City subcontractor may charge the City an additional fee. The Engineer may deduct the additional fee for said inspection and testing from a Progress Payment to the Contractor. The Engineer also may deduct the cost to perform additional testing when an initial test fails to meet the requirements of this Contract. The typical rates for material testing and inspection are available upon request from the Public Works Department.

(b) If the Contractor does not comply with a requirement of these Special Provisions or if it does not immediately respond, after being informed, to a request by the Engineer to amend a site condition that jeopardizes the public health, safety or welfare, the Engineer may direct City staff to perform the work. For each occurrence, the City will charge the Contractor a base charge in the amount of \$750 in addition to all costs incurred by the City for administration, labor, equipment and materials. The standard rates for City staff are available upon request from the Public Works Department.

(c) For each sign, drum, delineator, cone, barricade, warning device, or other type of required traffic control device that is not provided and/or replaced by the Contractor when required by the Traffic Control Plans and/or directed by the Engineer, the Engineer may deduct \$75 per day for each missing device from a Progress Payment.

(d) Temporary lane closures maintained prior to 8:30 A.M. and/or after 3:30 P.M. may have a negative economic effect on the local residential, commercial or industrial community. Unless otherwise specified in these Special Provisions, or directed by the Engineer a temporary lane closure is otherwise authorized, the Engineer may deduct a fee from a Progress Payment for each temporary lane closure maintained prior to 8:30 A.M. or after 3:30 P.M. The fee will be assessed at a rate of \$700 per each travel lane per each thirty (30) minute interval, or fraction thereof.

2-13 COORDINATION AND NOTIFICATIONS TO RESIDENTS AND BUSINESSES.

In order to provide adequate coordination of the work and timely notifications to the businesses and residences affected by the construction, the City will hold weekly field meetings lasting approximately one hour in which the City Project Engineer, Contractor foreman and/or superintendent and Inspector shall be present. Prior to beginning work, Contractor shall deliver written notices to each resident or business affected by the work which will be provided by the City. Any written communication to residents and/or businesses requires advance approval from the City. Contractor is to notify each resident or business of the proposed start of work date and estimated duration of work affecting said resident or business. In addition, Contractor shall be responsible to notify each resident or business of anticipated noise, odors, and access restrictions and shall coordinate with each resident or business to maintain access and security of the work site.

SECTION 3 – CHANGES IN WORK

3-2 CHANGES INITIATED BY THE AGENCY

3-2.2.1 General. Delete this subsection in its entirety. Add the following:

The City reserves the right to increase or decrease any bid item quantity, as necessary, to meet the City's needs and/or the project and/or budget requirements. If the City increases or decreases any bid item's original contract quantity by less than 25%, payment will be made at the original Contract Unit Price. If the City increases or decreases any bid item's original contract quantity by 25% or more than the original contract quantity, either the City or the Contractor may initiate discussions and/or negotiations regarding a potential adjustment to the contract unit bid price.

3-2.2.2 Increases of More Than 25%. Delete this subsection in its entirety.

3-2.2.3 Decreases of More Than 25%. Delete this subsection in its entirety.

3-3 EXTRA WORK 3-3.1 General. Add the following:

Payment for additional work and all expenditures in excess of the Contract Price must be authorized in writing by the Engineer. Such authorization shall be obtained by the Contractor prior to engaging in additional work. It shall be the Contractor's sole responsibility to obtain written approval from the Engineer for any change(s) in material or in the work proposed by suppliers or subcontractors. No payment shall be made to the Contractor for additional work which has not been approved in writing, and the Contractor hereby agrees that it shall have no right to additional compensation for any work not so authorized. The Contractor shall be responsible to provide all data and to obtain all approvals required by the Specifications, including submittal of Daily Extra Work Reports. No claims or extras shall be approved by the Engineer unless all work was done under the direction of and subject to the approval of the Engineer. Disputed work claims shall comply with 3-3 as modified herein.

3-3.2.2 Basis for Establishing Costs.

3-3.2.2.3 Tool and Equipment Rental. Replace the second paragraph of with the following:

The Contractor will be paid for the use of equipment at the lower of the actual rental rates paid by the Contractor or the rental rates listed for such equipment in either the "Rental Rate Blue Book" published by Dataquest, Inc., 1290 Ridder Park Drive, San Jose, California 95131; telephone (408) 971-9000 or the California Department of Transportation publication entitled "Labor Surcharge and Equipment Rental Rates" available at the Caltrans web site, <https://dot.ca.gov/programs/construction/equipment-rental-rates-and-labor-surcharge>, which is in effect on the date upon which the work is accomplished, and that hereby is made a part of the Contract, regardless of ownership or any rental or other agreement, if such may exist, for the use of such equipment entered into by the Contractor. If it is deemed necessary by the Engineer to use equipment not listed in the said publication, a suitable rental rate will be established by the Engineer. The Contractor may furnish any cost data that might assist the Engineer in the establishment of such rental rate.

3-3.2.3 Markup. Add the following:

The markups mentioned hereinafter shall include, but are not limited to, all costs for the services of superintendents, project managers, timekeepers and other personnel not working directly on the change order, and pickup or yard trucks used by the above personnel. These costs shall not be reported as labor or equipment elsewhere except when actually performing work directly on the change order and then shall only be reported at the labor classification of the work performed.

3-3.2.3.1 Work by Contractor. Replace the entire subsection with the following:

The following percentages shall be added to the Contractor’s costs and shall constitute the mark-up for all overhead and profit, which shall be deemed to include all items of expense not specifically designated as cost or equipment rental in Subsections 3-3.2.2.1, 3-3.2.2.2, and 3-3.2.2.3.

- Labor 20
- Materials 15
- Equipment Rental 15
- Other Expenditures 15

To the sum of the costs and markups provided for in this subsection, one (1) percent shall be added as compensation for bonding.

3-3.2.3.2 Work by Subcontractor. Replace the entire subsection with the following:

When any part of the extra work is performed by a subcontractor, the markup established in 3-3.2.3.1 shall be applied to the subcontractor’s actual cost of such work. A markup of ten (10) percent on the first \$5,000 of the subcontracted portion of the extra work and a mark-up of 5 percent on work added in excess of \$5,000 of the subcontracted portion of the extra work may be added by the Contractor.

The markups specified in the two subsections above shall be considered as including, but not limited to, the Contractor’s labor costs for personnel not working directly on the extra work, including the cost of any tools and equipment that they may use. Such costs shall not be reported as labor or equipment costs elsewhere except when they are actually used in the performance of the extra work. Labor costs shall in that case be reported for the labor classification corresponding to the type and nature of extra work performed.

3-4 CHANGED CONDITIONS. Add the following:

This subsection does not apply to utilities.

SECTION 4 – CONTROL OF MATERIALS

4-1 MATERIALS AND WORKMANSHIP.

4-1.1 General. Add the following paragraph after the second paragraph:

If the work, or any portion thereof, shall be damaged in any way, or if any defective materials or faulty workmanship shall be discovered at any time prior to the final payment, the Contractor shall forthwith, at its own cost and expense, repair said damage, or replace such defective materials, or remedy such faulty workmanship in a manner satisfactory to the Engineer.

4-1.2 Protection of Work and Materials. Add the following:

The Contractor shall assume all risks and expense of interference and delay in his operations, and the protection from or the repair of damage to improvements being built under the contract, as may be caused by water of whatever quantity from floods, storms, industrial waste, irrigation, underground or other sources. However, the Contractor shall be entitled to an extension of time in accordance with the provisions of Subsection 6-6. The Contractor shall also assume full responsibility and expense of protecting, or removing and returning to the site of Work, all equipment or materials under his care endangered by any action of the elements. Furthermore, the Contractor shall indemnify and hold the City harmless from all claims or suits for damages arising from his operations in dewatering the Work and control of water.

4-1.6 Trade Names or Equals. Replace the entire section with the following:

The Engineer will determine whether materials, products or systems, offered by Bidders as “Or Equal” products, materials or systems, are equivalent to those specified. Similarly, the Engineer will determine if substitute materials, products or systems, offered by Bidders in lieu of specified items, are satisfactory for utilization in lieu of specified items. Bidders must submit data concerning items desired to be considered as equal or substitution and at or before the time stipulated in the Notice Inviting Bids. Bidders submitting equals or substitute products, materials and systems must provide all product data, test reports and other relevant documentation and such that the Engineer can determine, without further inquiry or research, that the quality, strength, physical, chemical, or other characteristics, including durability, finish, efficiency, dimensions, service and suitability are such that the item will fulfill its intended function and properly integrate with all other affected project elements. The Engineer’s findings regarding all approved equal and/or substitute items will be communicated via an addendum to the bid documents prior to the bid date, and shall be final. For any “Or Equal” or substitute offered by bidders not found to be equal to the specified item or otherwise satisfactory by the Engineer, Bidders must include for furnishing and installing the specified item in their bids. The specified Contract completion time shall not be affected by any circumstance developing from the provisions of this subsection.

SECTION 5 – UTILITIES

5-1 LOCATION. Add the following:

The Contractor shall provide coordination with all the utility companies involved and shall provide protection from damage to their facilities. The Contractor shall be responsible for repair or replacement to said facilities made necessary by its failure to provide required protection. The Contractor is required to include utility requirements in the Construction Schedule per Section 6-1.

The Contractor shall utilize the services of "Underground Service Alert-Southern California" for utility locating in all public right-of-ways by calling 811 at least 48 hours prior to any excavation.

Pothole reports are available for review at the City. The new piping shall go over or under the existing utilities as indicated on the plans. Where not indicated, the Contractor shall assume that the new piping will cross under the existing utility. The Contractor shall pothole existing utilities as shown on the plans, as directed by the Engineer or as deemed necessary by the Contractor. The cost of potholing herein specified shall be included in the prices paid for other items of work and no additional compensation will be allowed.

Underground lines that are potentially hazardous such as oil company lines, natural gas mains, and electrical conduits will be carefully located by the owner as provided in the Standard Specifications. The Contractor shall take special precautions in determining the precise location and depth of these structures to ensure that they will not be damaged by its operations.

Substitute the following for the last paragraph:

Prior to starting construction, the Contractor shall be responsible to determine the location and depth of all utilities which have been marked by the respective owners and which may affect or be affected by its operations. The Contractor also shall determine the location and depth of each service connection, whether or not marked. Full compensation for such work shall be considered as included in the prices bid for other items or work. If a utility which was marked or a service connection is found to interfere with the work after construction has commenced, the Contractor shall be solely responsible for all costs of any delay and for any costs which could have been avoided if the Contractor had located the utility prior to start of construction.

5-2 PROTECTION. Add the following:

If, in the course of construction, the Contractor damages a sewer lateral or water lateral, the Contractor shall be responsible to completely expose said lateral from the main line to the point of connection at private property to verify integrity of all joints to the satisfaction of the Engineer. This shall not be considered to be extra work and no extra costs shall be allowed therefor.

Sewers, including lateral repairs, shall be constructed of Vitrified Clay Pipe, unless otherwise approved in writing by the Engineer.

Add the following after the final paragraph:

As noted in subsections 5-2.1, 5-2.2 and 5-2.3 utilities are classified and are to be handled in one of three ways by the Contractor in the course of performing the contract.

Add the following subsections:

5-2.1 Noninterfering Utilities Utilities that are not abandoned by the owner and do not physically interfere with the permanent work in its final location shall be supported, protected and maintained in place by the Contractor, and the Contractor shall be solely responsible for any damage, loss or injury, or death resulting from his/her failure to do so and the Contractor shall indemnify and hold harmless the City from any and all such consequences. Noninterfering utilities may, with the permission of the owner and the Public Works Director, be relocated still farther from the permanent work in its final locations, but the Contractor shall not so consider, in submitting his bid, unless the relocation is shown on the plans.

5-2.2 Abandoned Utilities Abandoned utilities are those portions of any utility which are no longer needed or desired by the owner and whose destruction is consented to by the owner and/or is permitted by notation on the plans. Abandoned utilities which physically interfere with the permanent work or with the construction thereof shall be removed by the Contractor and the Contractor shall be solely responsible for any damage, loss or injury, or death resulting from the removal and the Contractor shall indemnify and hold harmless the City from any and all such consequences.

5-2.3 Interfering Utilities Any utility shall be deemed an interfering utility (1) which physically occupies any part of the space to be occupied by the permanent work in its final locations, or (2) whose length within the theoretical width of excavation for the permanent work exceeds five times the width of said theoretical excavation whether or not the utility physically interferes with the permanent work. Interfering utilities that are not abandoned by the owner shall be relocated so as not to interfere with the permanent work in its final location. Such relocation will be performed by the owner or the City unless otherwise shown on the plans.

The Contractor shall exercise caution to prevent damage to or movement of the utilities while constructing the permanent work along and adjacent to the utilities.

Should any manhole extend within a trench excavation, the Contractor shall choose one of the following methods of construction and shall assume all responsibilities thereof:

- (1) Support and maintain the manholes in place during the construction of the permanent work in open cut.
- (2) Remove the shaft and maintain the base of the manhole in place until the backfill is placed and compacted; then reconstruct the manhole shaft.

(3) Use another method of construction which has been submitted to and approved by the Engineer. All costs for the work pertaining to the manholes that might be found to extend partially within the excavation limits or any protective measures required due to the proximity of the manholes and the permanent work at these locations shall be absorbed in the prices bid for the various items of work.

5-2.4 Protection of Underground Hazardous Utilities. This Subsection shall apply to projects where there are underground utilities within the Work area which may be potentially hazardous if damaged. A hazardous substance shall be defined as one having the potential for an immediate disaster such as, but not limited to, gasoline, electricity, fuel oil, butane, propane, natural gas, chlorine or other chemicals.

Abandoned or inoperative utilities designed to carry hazardous substances and unidentified or unknown utilities shall be considered hazardous until determined otherwise. Whenever the Contractor is directed by the Engineer to tap these lines, the Contractor shall provide personnel specialized in this work and payment therefore will be considered as extra work per 3-3 of these Special Provisions.

The Contractor shall comply with the following requirements when working around underground hazardous utilities:

1) The Contractor shall not trench or excavate within the area where a utility known to carry a hazardous substance exists until its location has been determined by excavation or other proven methods acceptable to the Engineer. The intervals between exploratory excavations or location points shall be sufficient to determine the exact location of the line. Unless otherwise directed by the Engineer, excavation for underground hazardous utilities shall be performed by the Contractor and paid for as specified per 5-1 of these Special Provisions.

2) If it is determined that the horizontal or vertical clearance between the utility known to carry hazardous substances and the construction limit is less than 300 mm (12 inches) (450mm (18 inches) if scarifying), the Contractor shall confer with its owner. Unless the owner elects to relocate the line or take it out of service, the Contractor shall not excavate until the line has been completely exposed within the limits of construction.

3) Once the physical location of the utility known to carry hazardous substances has been determined, the Contractor, in cooperation with and with the concurrence of the utility owner, shall determine how to protect and/or support the utility from damage before proceeding with the Work.

4) During all excavation and trenching operations, the Contractor shall exercise extreme caution and protect the utilities from damage.

5) The Contractor shall notify the Engineer, the public agency maintaining records for the jurisdiction in which the Project is located and the owner, if known, whenever previously unidentified or unknown underground utilities are encountered so that the location can be accurately established and made a part of permanent substructure records.

Full compensation for protecting underground hazardous utilities as specified or noted on the Plans shall be considered as included in the prices bid for the various items of work.

5-3 REMOVAL. Add the following:

It shall be the Contractor's responsibility irrespective of the notations on the plans to confirm or determine that a utility is to be abandoned before treating the same as an abandoned utility and shall assume all risks in so determining.

5-5 DELAYS. Substitute the following:

If the contractor while performing the contract discovers utility facilities not identified by the public agency in the contract plans or specifications, he shall immediately notify the City and utility in writing. The Contractor shall not be entitled to damage or additional payment, nor shall it be entitled to standby time for labor if a delay does occur. The Contractor also shall not be entitled to damage or additional payment for equipment not on the project during the occurrence of the event that caused the related delay. The Engineer will determine the extent of the delay attributable to such interferences, the effect of the delay on the project as a whole, and any commensurate extension of time.

Any failure of the City and/or utility company to accomplish relocations in a reasonable manner in light of the Contractor's operations (to the extent such operations would otherwise be feasible and in accordance with the contract and as disclosed to the City prior to the Contractor encountering any such utility) shall entitle the Contractor to an extension of contract time to the extent that, in the judgment of the Engineer, the Contractor's completion of the overall contract work has been delayed; however, the Contractor shall be entitled to no other remedy and, in submitting its bid, thereby waives such other remedies, if any, unless the relocation delay is the result of arbitrary, capricious or malicious conduct by the City.

SECTION 7 - RESPONSIBILITIES OF THE CONTRACTOR

7-9 PROTECTION AND RESTORATION OF EXISTING IMPROVEMENTS. Add the following paragraphs:

The Contractor shall be responsible to protect all new concrete work from being etched, scratched or otherwise marked or having wet slough material deposited thereon. If new concrete work is marked, the Contractor shall replace it at its expense in accordance with 303-5.7 of these special provisions.

The Contractor shall perform all private lawn, hardscape, and parkway restorations, (not included in the project plans) including restoration of irrigation systems and existing curb drains within five (5) days after the adjacent improvements have been constructed at his own expense. The Contractor shall not delay restorations for tree plantings.

Add the following subsections:

7-9.5 Protection of Existing Pavement Surfaces from Tack Coat and Oil. When work requires the placement of a tack coat pursuant to Subsection 302-5.4, the Contractor shall protect existing pavement surfaces outside of the work limits from the spreading of tack coat and oil adhering to vehicle tires exiting work area. The protected area shall extend the full width of the street and be by either of the following methods:

- 1) The Contractor shall wet the existing pavement surface to a distance of ten (10) feet away from the work limit. The wetted area shall be maintained as such until placement of asphalt concrete pavement is completed; OR
- 2) The Contractor shall provide a thin spreading of sand or rock dust material to a distance of five (5) feet away from the work limit. The sand or rock dust area shall be maintained as such until placement of asphalt concrete pavement is completed. The Contractor shall be responsible to remove the sand or rock dust immediately after the placement of asphalt concrete pavement is completed.

7-9.8 Protection of Raised Pavement Markers, Thermoplastic Legends and Markings. The Contractor shall, in areas outside of the work zone, protect existing raised pavement markers, paint and thermoplastic legends and markings. The Contractor shall remove by method of sandblasting, any existing thermoplastic or painted pavement legend or marking where indicated in these Specifications or on the Project Plans.

Remove traffic stripes and pavement markings, including paint in the gaps, by methods that do not materially damage the pavement. Remove a pavement marking such that the old message cannot be identified. If removing by grinding, make the grinding area rectangular. The minimum dimensions for the rectangular area are the height and width of the pavement marking. Sweep up or vacuum any residue before it can (1) be blown by traffic or wind, (2) migrate across lanes or shoulders, or (3) enter a drainage facility.

Existing raised pavement markers (blue, white, and yellow), thermoplastic “STOP” legends, 12-inch wide stop bars and other thermoplastic pavement markings that are not within the work area, but in close proximity shall either be masked to prevent damage or, if damaged, replaced in-kind.

The Contractor shall be responsible for replacing or restoring any damaged items to the satisfaction of the Engineer.

Full compensation for the items in this subsection shall be considered as included in the price paid for other items of work and no additional compensation will be allowed.

SECTION 9 - MEASUREMENT AND PAYMENT

9-1 MEASUREMENT OF QUANTITIES FOR UNIT PRICE WORK.

9-1.2 Methods of Measurement. Add the following subsections:

9-1.2.1 Payment for Labor and Materials.

The Contractor shall pay and cause the subcontractors to pay any and all accounts for labor, including Worker's Compensation premiums, State Unemployment and Federal Social Security payments and all other wage and salary deductions required by law. The Contractor also shall pay and cause the subcontractors to pay any and all accounts for services, equipment and materials used by it and the subcontractors during the performance of work under this contract. All such accounts shall be paid as they become due and payable. If requested by the Engineer, the Contractor shall immediately furnish the City with proof of payment of such accounts.

9-1.2.2 Measurement and Payment Payment of each item will include full compensation for furnishing all labor, materials, tools, equipment and backup equipment; transportation and technical competence for performing all work necessary to complete each item as indicated on the plans and as specified in these Contract Documents, including but not limited to obtaining all applicable certifications necessary for specialty personnel and major equipment in conformance with Subsection 7-5, and all other applicable permits; securing a storage yard to store all equipment and materials to be used on the job, disposal of waste materials, restoration of the site, etc. The storage yard may also be used as a temporary storage for excavated materials, and traffic control items. Costs for mobilization/demobilization shall be included in the Contract Unit Price for MOBILIZATION.

9-2 LUMP SUM WORK. Replace the second paragraph with the following:

The Contractor shall, within five (5) working days of receipt of a request from the Engineer, submit a complete breakdown of lump sum bid prices showing the value assigned to each part of the work, including an allowance for profit and overhead. In submitting the breakdown, the Contractor certifies that it is not unbalanced and that the value assigned to each part of the work represents its estimate of the actual cost, including profit and overhead, of performing that part of the work. The breakdown shall be sufficiently detailed to permit its use by the Engineer as one of the bases for evaluating requests for payment. No extra costs shall be allowed for providing these breakdowns.

Lump sum bid items that are to be implemented throughout the project duration, including but not limited to TRAFFIC CONTROL and MOBILIZATION shall be paid in proportion to the percentage of working days elapsed relative to the project duration.

9-3 PAYMENT.

9-3.2 Partial and Final Payment. Replace the third paragraph with the following:

For each progress estimate, 5 percent will be deducted and retained by the CITY, and the remainder less the amount of all previous payments will be paid. In addition, 125% of the amount of unreleased "STOP" Notices will be withheld.

Add the following:

The Contractor shall submit all requests for payment on a Progress Payment Invoice. Prior to submittal of said invoice, all items for which payment is requested shall be checked and approved in writing by the Engineer. No payments will be made unless all back-up data is submitted with the payment request and the Progress Payment Invoice is signed by both Contractor and Engineer.

Back up data required to process payment shall include but not limited to the following: Conditional and Unconditional lien releases from contractor, subcontractor and suppliers from which the contractor is expecting payment.

Release forms must reflect amount of draw and through date of invoice payment.

1. Conditional releases for the current pay period shall be provided with the current payment request.
2. Unconditional releases for the immediate prior pay period shall be provided with the current payment request. Unconditional lien release forms must match the preceding Conditional release form in amount and through date and must be signed authorized company representative. Unconditional Lien Release on Final Payment with a zero balance is required from all material suppliers and subcontractors with the request for final payment (retention). All Unconditional Lien Release on Final Payments will be signed authorized company representative and notarized. Release forms can be found at the Contractors State License Board website at https://www.cslb.ca.gov/Consumers/Legal_Issues_For_Consumers/Mechanics_Lien/Conditional_And_Unconditional_Waiver_Release_Form.aspx. The most update current lien release forms must be used.

9-3.4 Mobilization. Replace the entire subsection with the following:

Mobilization shall include the provisions of the Construction Schedule, Best Management Practices and Storm Water Pollution Prevention Plan; Sewage Spillage Prevention; Emergency Response Plan; site review; obtaining all permits, insurance, and bonds; moving onto the site all plant and equipment; furnishing and erecting plants, temporary buildings, and other construction facilities, and removal of same at completion of the Work; and other work, all as required for the proper performance and completion of the Work.

Mobilization shall include, but not be limited to, the following items:

- (a) Submittal and modification, as required, of the Construction Schedule.
- (b) Moving on to the site of all Contractor's plant and equipment required for the first month's operations.

- (c) Installing temporary construction power and wiring.
- (d) Establishing fire protection system.
- (e) Developing construction water supply.
- (f) Providing on-site sanitary facilities and portable water facilities, as required.
- (g) Arranging for and erection of Contractor's work and storage yard.
- (h) Submittal of all required insurance certificates and bonds, including subcontractors.
- (i) Obtaining all required permits.
- (j) Posting all OSHA required notices and establishment of safety programs.
- (k) Potholing and other research and review as necessary to verify site conditions and utility locations.
- (l) Having the Contractor's Superintendent present at the job site full-time.
- (m) Removal (including all spray-painted markings on any surface), cleanup, and restoration.

Payment for mobilization after completion of Items (a) through (l) above shall be limited to no more than 25% of the total bid for mobilization. Payment for mobilization will then be paid proportionate to the percent complete of the project in relation to its working days and up to an amount no more than 90% until the Contractor completes Item (m).

Add the following subsection:

9-3.5 Noncompliance with Plans and Specifications.

Failure of the Contractor to comply with any requirement of the Plans and Specifications, and/or to immediately remedy any such noncompliance upon notice from the Engineer, may result in suspension of Contract Progress Payments. Any Progress Payments so suspended shall remain in suspension until the Contractor's operations and/or submittals are brought into compliance to the satisfaction of the Engineer. No additional compensation shall be allowed as a result of suspension of Progress Payments due to noncompliance with the plans or specifications. The Contractor shall not be permitted to stop work due to said suspension of Progress Payments. Add the following section:

9-4 CLAIMS.

The Contractor shall not be entitled to the payment of any additional compensation for any cause, including any act, or failure to act, by the CITY, or the happening of any event, thing or occurrence, unless the Contractor shall have given the CITY due written notice of potential claim as hereinafter specified.

The written notice of potential claim shall set forth the reasons for which the Contractor believes additional compensation will or may be due, the nature of the costs involved, and, insofar as possible, the amount of the potential claim. Said notice shall be submitted on a form approved by the CITY at least forty-eight (48) hours (two working days) in advance of performing said work, unless the work is of an emergency nature, in which case the Contractor shall notify and obtain approval from the Engineer prior to commencing the work. The Engineer may require the Contractor to delay construction involving the claim, but no other work shall be delayed, and the

Contractor shall not be allowed additional costs for any said delay but may be allowed an extension of time if the Engineer agrees that the work delayed is a controlling element of the Construction Schedule. The Contractor shall be required to submit any supporting data (or a detailed written explanation justifying further delay) within five (5) work days of a request from the Engineer and shall be responsible for all costs associated with any delays resulting from late and/or incomplete submittals. By submitting a Bid, the Contractor hereby agrees that this subsection shall supersede 6-6.3 and 6-6.4 of the Standard Specifications.

It is the intention of this subsection that differences between the parties arising under and by virtue of the Contract be brought to the attention of the Engineer at the earliest possible time in order that such matters may be settled, if possible, or other appropriate action promptly taken. The Contractor hereby agrees that it shall have no right to additional compensation for any claim that may be based on any such act, failure to act, event, thing or occurrence for which no written notice of potential claim as herein required was timely filed.

PART 2 - CONSTRUCTION MATERIALS

SECTION 210 – PAINT AND PROTECTIVE COATINGS

210-1 PAINT

Add the following subsection:

210-1.6 Paint for Traffic Striping, Pavement Marking, and Curb Marking

210-1.6.1. General.

Locations where all traffic striping and pavement markings shall be installed are listed in Part 6: Description of Bid Items. At these locations, two coats of paint shall be installed over existing traffic stripes and pavement markings. All turn pocket line extensions and all directional lane lines through the intersections shall be cat-tracked and painted with two coats of paint.

Locations where all traffic striping and pavement markings shall be removed and reinstalled are listed in Part 6: Description of Bid Items. At these locations, all striping shall be thermoplastic.

All thermoplastic crosswalks shall be removed and replaced. All paint crosswalks shall be refreshed with two coats of paint over existing crosswalk lines. The locations and types of crosswalks are listed in Part 6: Description of Bid Items.

Actual limits are to be determined in the field by the Engineer.

All thermoplastic on arterial and collector streets shall be hot applied alkyd thermoplastic in accordance with the provisions of Section 84-2.02 of the Caltrans Standard Specifications.

210-1.6.2 Thermoplastic Paint, Paint, State Specifications. Traffic stripes and pavement markings shall conform to the provisions of Section 84 of the Caltrans Standard Specifications. Contractor shall paint a solid black stripe between all double thermoplastic striping.

Add the following subsection:

210-1.7 Test Reports and Certifications At the time of delivery of each shipment of material, the Contractor shall, upon request, deliver to the Engineer certified copies of manufacturer's test report. The test report shall indicate the name of manufacturer, type of material, date of manufacture, quantity, State Specification number, manufacturer's lot or batch number, and results of the required tests. The test report shall be signed by an authorized representative of the manufacturer. The certified test reports and the testing required in connection therewith shall be at no cost to the CITY.

SECTION 214 – TRAFFIC STRIPING, CURB AND PAVEMENT MARKINGS, AND PAVEMENT MARKERS

Delete the entire Section 214 and replace with Sections 81 and 85 of the Caltrans Standard Specifications (2018 edition).

81-3 PAVEMENT MARKERS

81-3.02D Hot Melt Bituminous Adhesive. Add the following:

At the option of the Contractor, a hot melt bituminous adhesive may be used to cement the markers to the pavement, instead of the Rapid Set Type or Standard Set Type adhesive specified in Section 81-3.02E of the Caltrans Standard Specifications. The bituminous adhesive material, if used, shall conform to the following:

<u>ASTM Test Specification</u>	<u>Method</u>	<u>Requirement</u>
Flash Point, COC oF	D 92	550 Min.
Softening Point, oF	D 36	200 Min.
Brookfield Viscosity, 400 oF	D 2196	3,000- 400o F 7,500 cP
Penetration, 100g 5 sec., 77o F	D 5	10-20 dmm
Filler Content, % by weight (Insoluble in 1,1,1 Trichloroethane)	D 2371	50-75

PART 3 - CONSTRUCTION METHODS

SECTION 310 – PAINTING

310-5 PAINTING VARIOUS SURFACES.

Use Sections 84-1 and 84-2 of the Caltrans Standard Specifications.

SECTION 84: TRAFFIC STRIPES AND PAVEMENT MARKINGS

84-1.01 Description. Replace the first two paragraphs with the following:

This work shall consist of applying two coats of paint on traffic stripes (traffic lines) and pavement markings at the locations and in accordance with the details shown on the Plans or designated by the Engineer, and as specified in these Specifications and Special Provisions, including but not limited to all left-turn pocket line extensions.

The thermoplastic material shall conform to the provisions of 84-2.02 of the Caltrans Standard Specifications.

All crosswalk striping on concrete pavement shall be paint. All crosswalk striping on asphalt concrete pavement shall be thermoplastic.

All traffic lines shall be 4 inches wide, unless otherwise shown on the Plans or directed by the Engineer. All turn pockets shall include an 8-inch wide white skip line extension (Detail 40) per Caltrans Revised Standard Plan A20D.

All lines through intersections shall be 4-inch wide white skip line extensions (Detail 40) per Caltrans Revised Standard Plan A20D.

84-2.06 Payment. Replace the entire subsection with the following:

Payment for REMOVE AND INSTALL 12 INCH WIDE CROSSWALK STRIPE PER CALTRANS STANDARD PLAN A24F (THERMOPLASTIC) shall be on a lump sum basis per the Contract Unit Price and shall include full compensation for furnishing all labor, materials, tools, equipment, and incidentals, necessary to complete the Work.

All costs for establishing alignment of traffic stripes, pavement markings, layout, temporary pavement painting, and sandblasting of existing lines and markings shall be included and no extra costs will be allowed.

SECTION 314 – TRAFFIC STRIPING, CURB AND PAVEMENT MARKINGS, AND PAVEMENT MARKERS

Delete the entire Section 314 and replace with Sections 85-1.06 and 85-1.09 of the Caltrans Standard Specifications.

85-1.06 Placement. Add the following:

The solid 4” white lines at intersections shall have a marker installed at each end. These markers shall be placed on the line.

Markers shall not be installed on bike lane striping.

Where pavement markers are missing or damaged, Contractor shall install new markers at the locations required per Caltrans Standard Plans A20A, RSP A20B, RSP A20C, RSP A20D, RSP A20E, RSP A20F, and RSP A20G for the applicable existing line type.

85-1.09 Payment. Add the following:

There shall be no separate payment for pavement markers. Full compensation for furnishing all labor, materials, tools, equipment and incidentals, and for doing all the work involved in furnishing and placing pavement markings, complete in place, including adhesives and establishing alignment for pavement markers, as shown on the Plans, and specified in these Special Provisions shall be included in the Contract Unit Price for traffic striping and pavement markers as described in Section 84-2.06 of these Special Provisions.

PART 6 – DESCRIPTION OF BID ITEMS

Bid Item No. 1 – TRAFFIC CONTROL

This item includes the cost of work area traffic control, pedestrian access, installation and removal of temporary pavement markers / delineation and signs. Payment for this item shall be lump sum and shall include compensation for all costs incurred under this item.

Bid Item No. 2 – MOBILIZATION

This item includes the cost of mobilization and demobilization. The specifics are discussed at the job walk. Payment for this item shall be lump sum and shall include compensation for all costs incurred under this item.

Bid Item No. 3 – REMOVE AND INSTALL 12 INCH WIDE CROSSWALK STRIPE PER CALTRANS STANDARD PLAN A24F (THERMOPLASTIC)

This item includes the cost of removal and replacement of a single 12-inch wide crosswalk line. The specifics are outlined in Sections 310 and 314. Payment for this item shall be lump sum of 12 inch wide thermoplastic stripe and shall include compensation for all costs incurred under this item. Intersections with crosswalks of this type are listed below:

Locations:

- 147th Street and Freeman Ave
- 147th Street and Eastwood Ave
- 147th Street and Osage Ave

Actual limits are to be determined in the field by the Engineer.

APPENDIX A

PROJECT LOCATION MAP

Project Limits

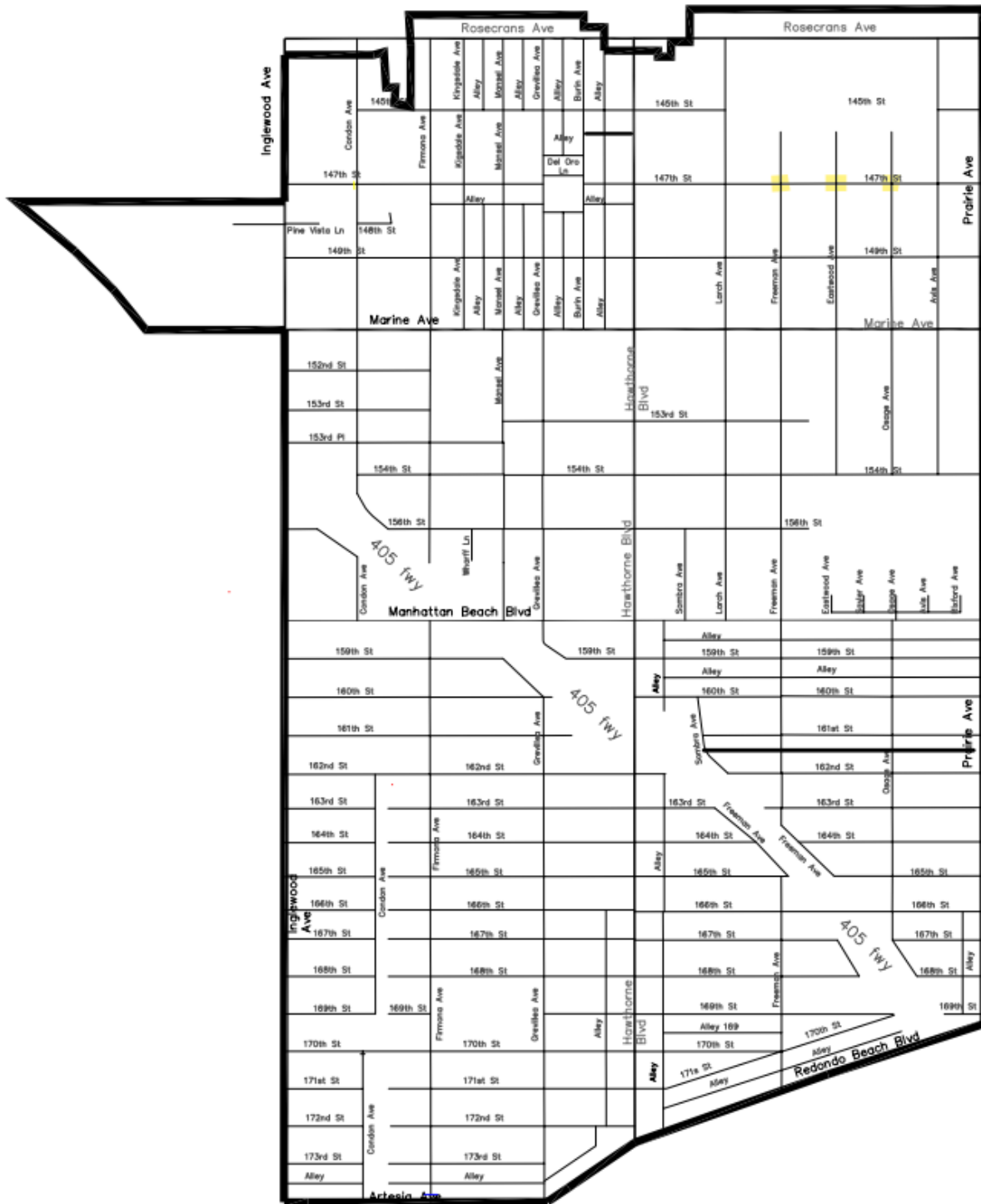

APPENDIX B

CALTRANS STANDARD PLANS

STATE COUNTY ROUTE HIGHWAY TOTAL PROJECT SHEET NO. 1 OF 1

Oliver Young

May 31, 2018

REVISED PLAN SHEET

DATE: 05/31/18

PROJECT: STATE ROUTE 152

CONTRACT: 152-100-000

SECTION: 152-100-000

SCALE: AS SHOWN

NO PASSING ZONES-TWO DIRECTION

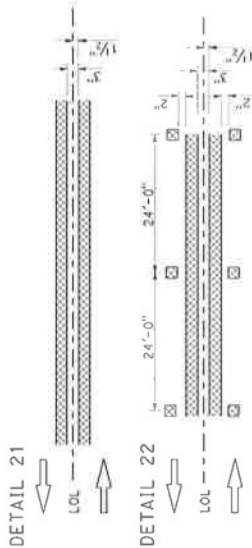

DETAIL 23 DELETED

DETAIL 23 DELETED

LANELINES (Cont)



DETAIL 13 DELETED

DETAIL 14 DELETED

DETAIL 14A DELETED

NO PASSING ZONES-ONE DIRECTION

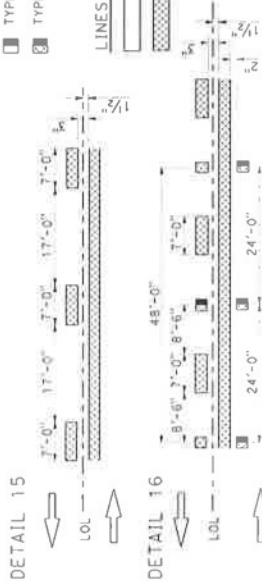

DETAIL 17 DELETED

DETAIL 17 DELETED

DETAIL 18 DELETED

DETAIL 18 DELETED

DETAIL 19 DELETED

DETAIL 19 DELETED

DETAIL 20 DELETED

DETAIL 20 DELETED

CENTERLINES

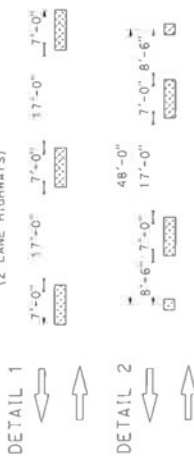

DETAIL 3 DELETED

DETAIL 4 DELETED

DETAIL 5 DELETED

DETAIL 5 DELETED

DETAIL 6 DELETED

DETAIL 6 DELETED

DETAIL 7 DELETED

DETAIL 7 DELETED

LANELINES

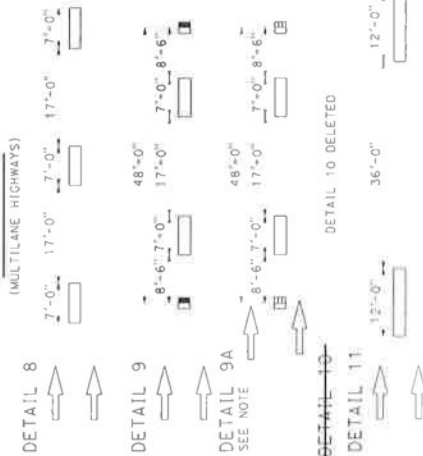

DETAIL 10 DELETED

DETAIL 11 DELETED

DETAIL 11 DELETED

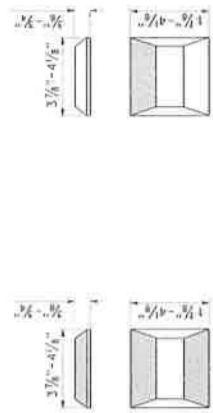

TYPE C AND TYPE D

RETROREFLECTIVE PAGE

TYPE G AND TYPE H

STATE OF CALIFORNIA
DEPARTMENT OF TRANSPORTATION
**PAVEMENT MARKERS
AND TRAFFIC LINES
TYPICAL DETAILS**

NO SCALE

A20A

© 2019 California Department of Transportation
All Rights Reserved

LEFT EDGE LINES
(DIVIDED HIGHWAYS)
See Note

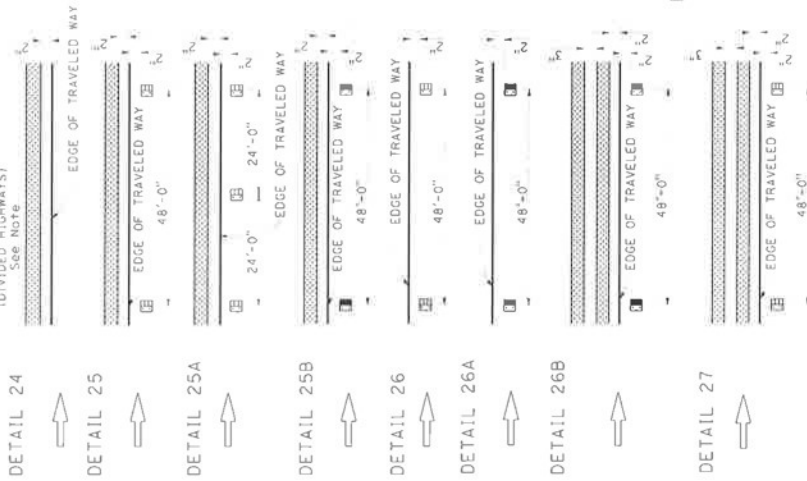

RIGHT EDGE LINES



RIGHT EDGE LINE EXTENSION THROUGH INTERSECTIONS



LEGEND

- MARKERS**
- TYPE D
 - TYPE H
 - TYPE RY
- RETROREFLECTIVE**
- TYPE D
 - TYPE H
 - TYPE RY

MEDIAN ISLANDS

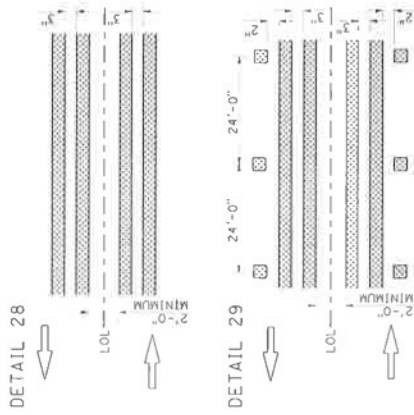

INTERSECTION TREATMENTS

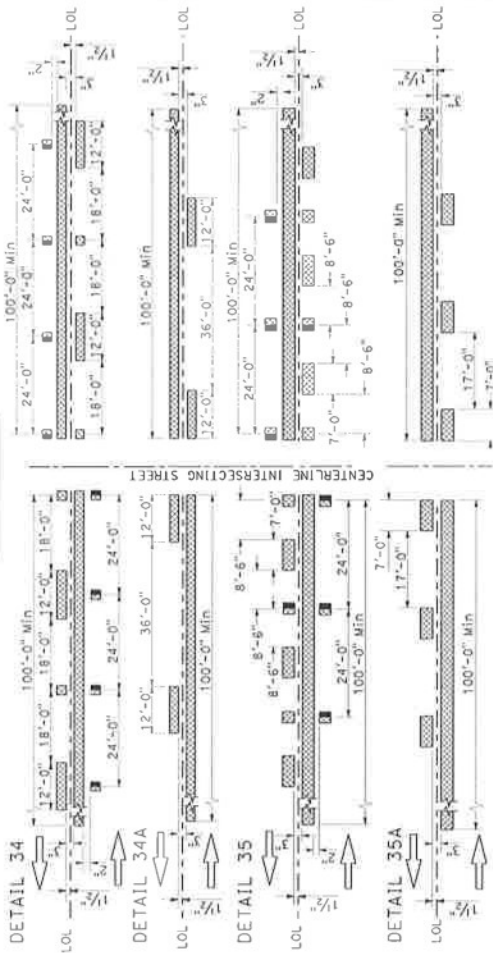

TWO-WAY LEFT TURN LANES

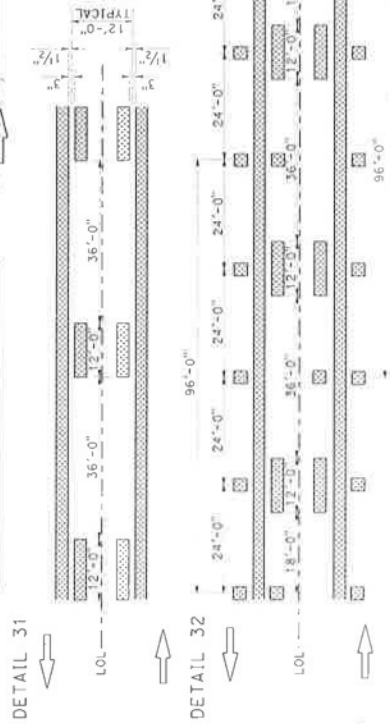

MARKER DETAILS

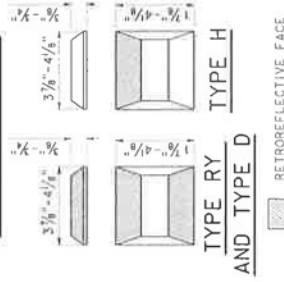

STATE OF CALIFORNIA
DEPARTMENT OF TRANSPORTATION

PAVEMENT MARKERS AND TRAFFIC LINES TYPICAL DETAILS

NO SCALE

RSP A20B DATED APRIL 19, 2019 SUPERSEDES STANDARD PLAN A20B
DATED MAY 31, 2018 - PAGE 13 OF THE STANDARD PLANS BOOK DATED 2016.

REVISED STANDARD PLAN RSP A20B

LEFT EDGE LINES NOTE:
On freeways use traffic stripe details with Type RY markers.

© 2020 California Department of Transportation
All Rights Reserved

EXIT RAMP NEUTRAL AREA (GORE) TREATMENT

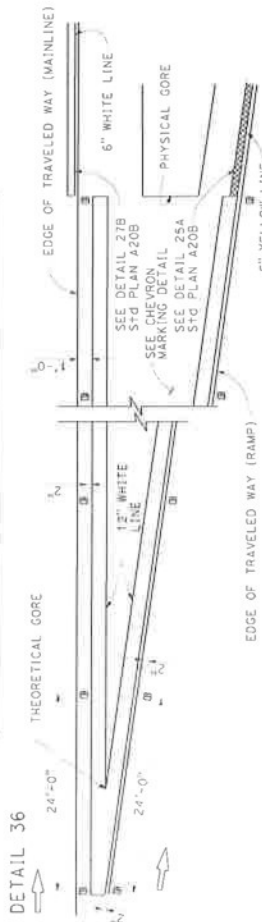

NOTES:
Install a minimum of 1 chevron in the gore area. If at least 1 chevron will not fit into the gore area, do not install chevrons. Terminate chevron markings at physical gore.
Gore area chevron pavement markings shown for Exit and Entrance Ramp channelizing lines details; see Details 36, 36A, and 36B.

TO ACCOMPANY PLANS DATED
April 17, 2020
RSP A20C DATED OCTOBER 19, 2018 AND STANDARD PLAN A20C DATED MAY 31, 2018 - PAGE 14 OF THE STANDARD PLANS BOOK DATED 2018.

ENTRANCE RAMP NEUTRAL AREA (MERGE) TREATMENT

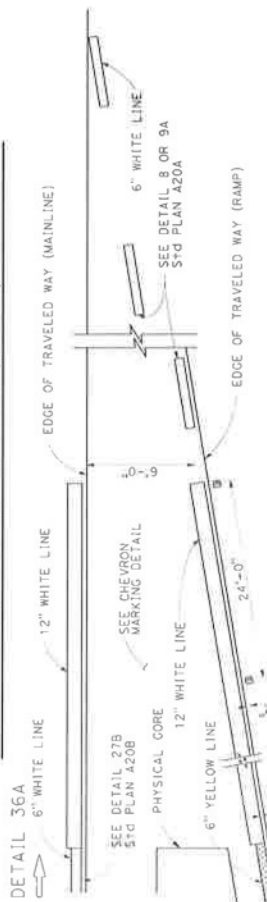

ENTRANCE RAMP NEUTRAL AREA (ACCELERATION LANE) TREATMENT

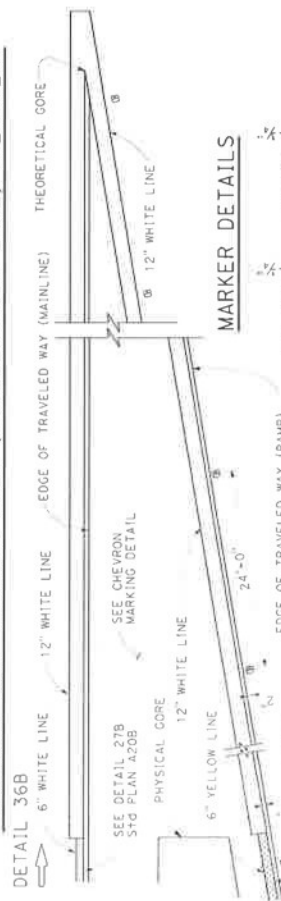

LANE DROP AT EXIT RAMP

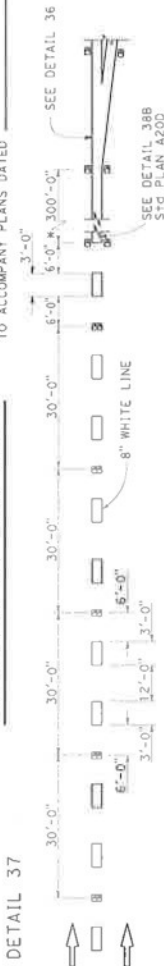

* The solid channelizing line shown may be omitted on short auxiliary lanes where weaving length is critical.
DETAIL 37A DELETED

LANE DROP AT INTERSECTIONS

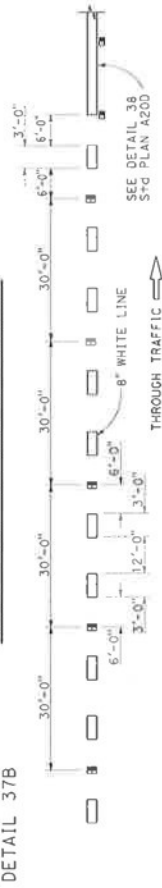

DETAIL 37C DELETED

CHEVRON PAVEMENT MARKINGS AT EXIT RAMP GORE AREA

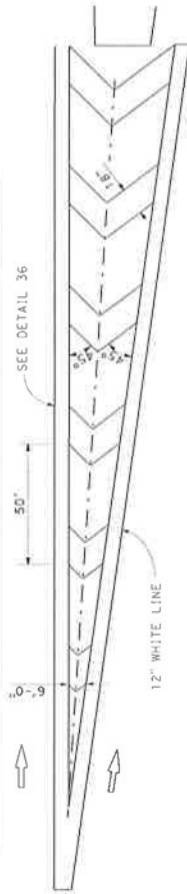

CHEVRON PAVEMENT MARKINGS AT ENTRANCE RAMP GORE AREA

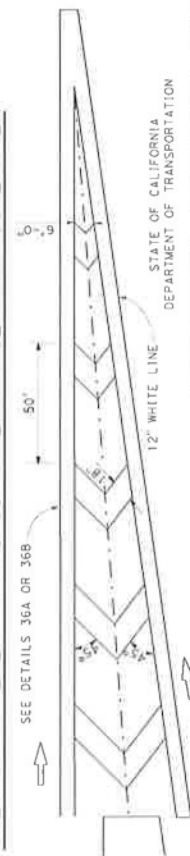

STATE OF CALIFORNIA
DEPARTMENT OF TRANSPORTATION

PAVEMENT MARKERS AND TRAFFIC LINES TYPICAL DETAILS

NO. SCALE

RSP A20C DATED APRIL 17, 2020 SUPERSEDES RSP A20C DATED OCTOBER 19, 2018 AND STANDARD PLAN A20C DATED MAY 31, 2018 - PAGE 14 OF THE STANDARD PLANS BOOK DATED 2018.

REVISED STANDARD PLAN RSP A20C

LEGEND:

MARKERS

- TYPE C RED-CLEAR RETROREFLECTIVE
- TYPE G ONE-WAY CLEAR RETROREFLECTIVE
- TYPE RY RED-YELLOW RETROREFLECTIVE

TYPE C AND TYPE G
TYPE RY RETROREFLECTIVE FACE

MARKER DETAILS

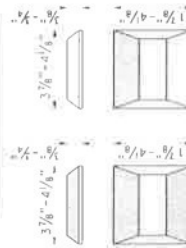

© 2018 California Department of Transportation
All Rights Reserved

CHANNELIZING LINE

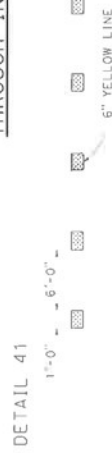

LEGEND
MARKERS

- TYPE C RED-CLEAR RETROREFLECTIVE
- TYPE G ONE-WAY CLEAR RETROREFLECTIVE
- 6" YELLOW LINE

MARKER DETAILS

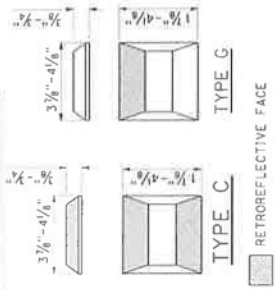

DETAIL FOR RECESSED TRAFFIC STRIPE
See Notes A and B.

- RECESSED NOTES:**
- A. See typical traffic line details for pavement marking patterns.
 - B. See standard specifications for recess depth and recess striping material thickness.

LANE LINE EXTENSIONS THROUGH INTERSECTIONS

DETAIL 40A DELETED

CENTER LINE EXTENSIONS THROUGH INTERSECTIONS

DETAIL 41A DELETED

DATE: OCTOBER 19, 2018
PROJECT: CALIFORNIA HIGHWAY 99
DRAWN BY: [Signature]
CHECKED BY: [Signature]
SCALE: AS SHOWN
SHEET NO. 1 OF 1

TO ACCOMPANY PLANS DATED

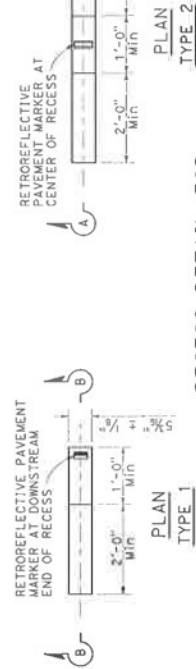

RECESS DETAIL FOR RETROREFLECTIVE PAVEMENT MARKER
See Note 4

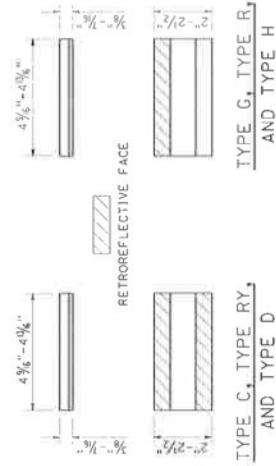

RETROREFLECTIVE PAVEMENT MARKER FOR RECESSED INSTALLATION
See Notes 1 and 2.

- RECESSED MARKER NOTES:**
1. See typical traffic line details for marker patterns to be used with recessed pavement markers.
 2. The retroreflective shown for recessed installations are not to be used for non-recessed installations.
 3. The top of pavement recesses shall be 0 to 3/8" below the pavement surface.
 4. Use Type 1 recess for both one-way and two-way retroreflective face. Use Type 2 recess for pavement markers with two-way retroreflective face.

STATE OF CALIFORNIA
DEPARTMENT OF TRANSPORTATION

PAVEMENT MARKERS AND TRAFFIC LINES TYPICAL DETAILS

NO SCALE

RSP A20D DATED OCTOBER 19, 2018. SUPERSEDES STANDARD PLAN A20D DATED MAY 31, 2018 - PAGE 19 OF THE STANDARD PLANS BOOK DATED 2018.

© 2019 California Department of Transportation
All Rights Reserved

COUNTY	ROUTE	POST MILEAGE	POST MILEAGE	POST MILEAGE

Alfred Young

April 19, 2019

PROJECT NO. 2-21-21

DATE 4/19/19

BY [Signature]

FOR APPROVAL OF CONTRACT BY OWNER

FOR APPROVAL OF CONTRACT BY ENGINEER

FOR APPROVAL OF CONTRACT BY DESIGNER

FOR APPROVAL OF CONTRACT BY SUBMITTER

FOR APPROVAL OF CONTRACT BY REVIEWER

FOR APPROVAL OF CONTRACT BY APPROVER

TO ACCOMPANY PLANS DATED _____

NOTE:

- 1. See Standard Plans A20A, A20B, A20C, A20D, and A20E for pavement markers and traffic lines typical details.



TYPICAL LANE LINE OR RIGHT EDGE LINE CONTRAST DETAIL

STATE OF CALIFORNIA
DEPARTMENT OF TRANSPORTATION

**PAVEMENT MARKERS
AND TRAFFIC LINES**

TYPICAL DETAIL FOR CONTRAST STRIPING

NO SCALE

RSP A20E DATED APRIL 19, 2019 SUPERSEDES STANDARD PLAN A20E
DATED MAY 31, 2018 - PAGE 16 OF THE STANDARD PLANS BOOK DATED 2018.

REVISED STANDARD PLAN RSP A20E

© 2019 California Department of Transportation
All Rights Reserved

DATE	COLN	ROUTE	WORK	SECTION	SHEET

Oliver Young
REGISTERED CIVIL ENGINEER

April 19, 2019

STATE OF CALIFORNIA
DEPARTMENT OF TRANSPORTATION
STANDARD PLAN RSP A20F
PAVEMENT MARKERS AND TRAFFIC LINES
TYPICAL DETAILS
REVISED OCTOBER 15, 2018

TO ACCOMPANY PLANS DATED

PREFERENTIAL LANE LINES



DETAIL 42



DETAIL 43



DETAIL 43A



DETAIL 44A

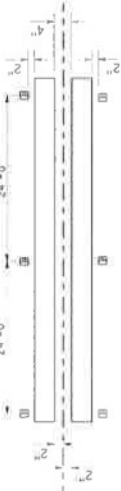

DETAIL 44B

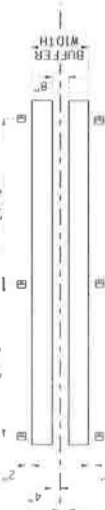

DETAIL 45

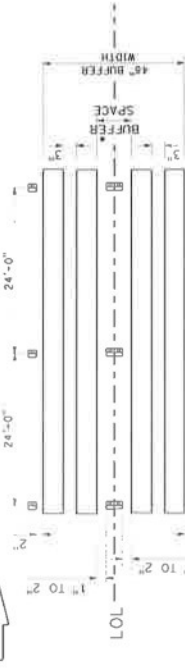

* If buffer space is wider than 4 feet use chevron markings.

LEGEND

MARKERS

TYPE C RED-CLEAR RETROREFLECTIVE

LINE

8" WHITE LINE

MARKER DETAILS

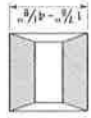
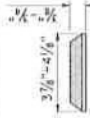

TYPE C

RETROREFLECTIVE FACE

STATE OF CALIFORNIA
DEPARTMENT OF TRANSPORTATION
**PAVEMENT MARKERS
AND TRAFFIC LINES
TYPICAL DETAILS**

NO SCALE

RSP A20F DATED APRIL 15, 2019 SUPERSEDES RSP A20F
DATED OCTOBER 15, 2018 THAT SUPPLEMENTS TO THE STANDARD PLANS BOOK DATED 2018.

REVISED STANDARD PLAN RSP A20F

© 2021 California Department of Transportation
All Rights Reserved

STATE COUNTY POST OFFICE ADDRESS NO. CITY STATE ZIP
 REGISTERED CIVIL ENGINEER
 April 16, 2021
 PROJECT NO. 080602
 DATE 3-31-21
 PROJECT TITLE
 SHEET NO. 101 OF 101

TO ACCOMPANY PLANS DATED

NOTES:

1. May be a limit line or crosswalk.
2. See standard plan A24F and Revised Standard Plan RSP A24G for crosswalk and pavement marker details.
3. Place Type R one-way red retroreflective markers on outermost limit line or crosswalk line with red facing the intersection.
4. The distances and marker spacings may be adjusted based on site specific conditions or exit ramp geometry.
5. The layout shown is a typical detail of an exit ramp, see Figure 3B-24 of the CA MUTCD for exit ramp configuration and arrow placement and spacing.
6. See Revised Standard Plan RSP A24G for Type V arrow detail with Type R one-way red retroreflective markers.

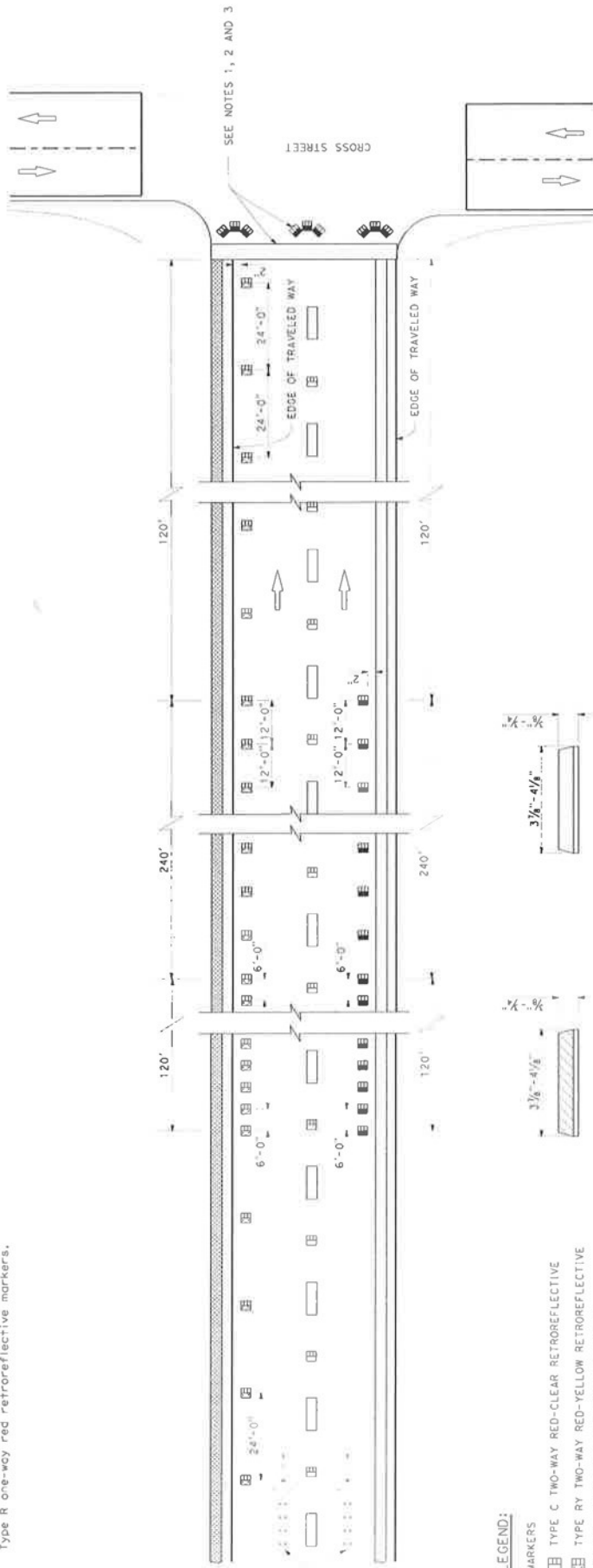

LEGEND:

- MARKERS**
- ▢ TYPE C TWO-WAY RED-CLEAR RETROREFLECTIVE
 - ▢ TYPE RY TWO-WAY RED-YELLOW RETROREFLECTIVE
 - ▢ TYPE R ONE-WAY RED RETROREFLECTIVE

LINES

- ▬ 6" WHITE
- ▬ 6" YELLOW

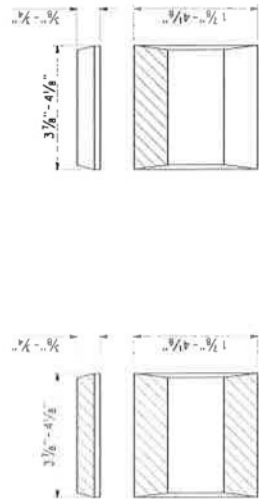

TYPE C AND TYPE RY

TYPE R

MARKER DETAILS



STATE OF CALIFORNIA
DEPARTMENT OF TRANSPORTATION

EXIT RAMP WITH ENHANCED PAVEMENT MARKERS FOR WRONG WAY DETAILS

NO SCALE

RSP A20G DATED APRIL 16, 2021 SUPPLEMENTS THE STANDARD PLANS BOOK DATED 2018.

REVISED STANDARD PLAN RSP A20G

STAFF COUNTY # _____ COUNTY # _____ DISTRICT # _____

Clifford Ferry
 STATE OF CALIFORNIA
 REGISTERED PROFESSIONAL ENGINEER
 No. 45167
 Exp. 3-31-19

May 31, 2018

PROJECT: _____
 SHEET: _____

FOR AS-built, THIS PLAN IS UNDESIGNED FOR CONSTRUCTION OF ANY PARTS.

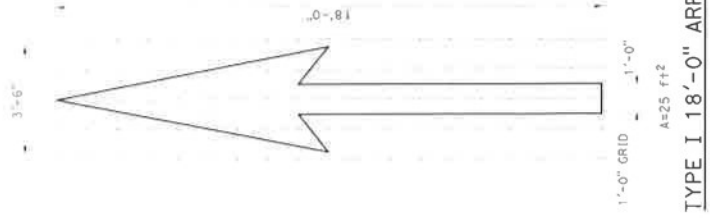
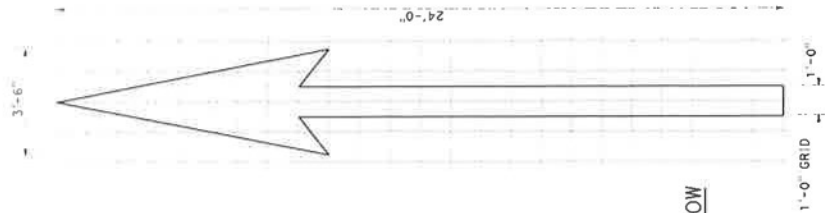
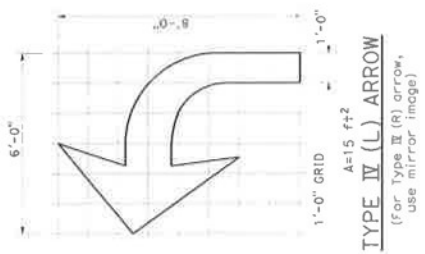
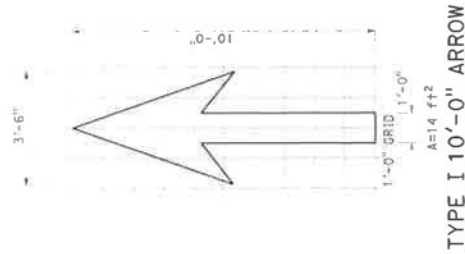
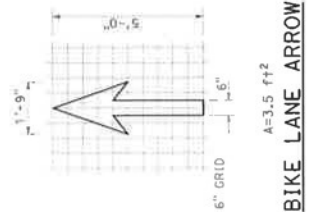
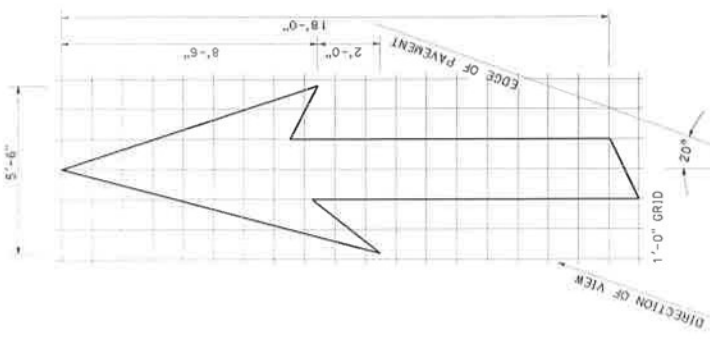
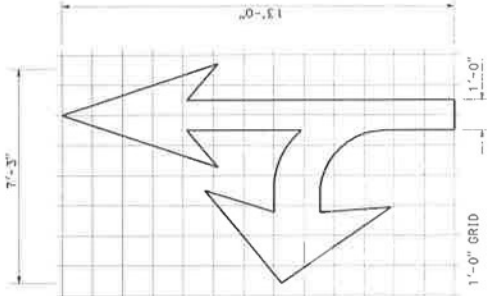
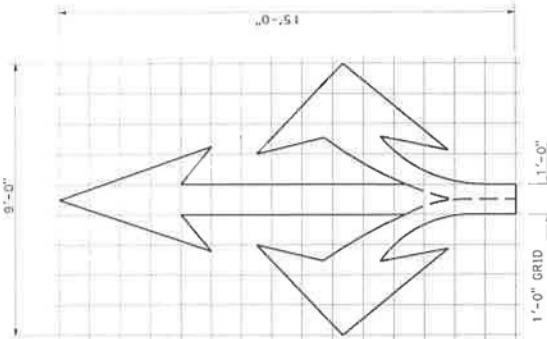

NOTE:
 Minor variations in dimensions
 may be accepted by the Engineer.

STATE OF CALIFORNIA
 DEPARTMENT OF TRANSPORTATION
**PAVEMENT MARKINGS
 ARROWS**
 NO SCALE

A24A

STATE ENGINEER
 REGISTERED PROFESSIONAL ENGINEER
 OFFICE: 1500 J STREET, SUITE 200, SACRAMENTO, CA 95811
 TELEPHONE: (916) 445-7000
 FAX: (916) 445-7001
 MAILING ADDRESS: 1500 J STREET, SUITE 200, SACRAMENTO, CA 95811
 LICENSE NO. 47827
 EXPIRES: 06/30/2020

Clayton Ferry
 CIVIL ENGINEER
 REGISTERED PROFESSIONAL ENGINEER
 OFFICE: 1500 J STREET, SUITE 200, SACRAMENTO, CA 95811
 TELEPHONE: (916) 445-7000
 FAX: (916) 445-7001
 MAILING ADDRESS: 1500 J STREET, SUITE 200, SACRAMENTO, CA 95811
 LICENSE NO. 47827
 EXPIRES: 06/30/2020

DATE: May 31, 2018
 PROJECT: [REDACTED]
 SHEET: [REDACTED]
 TOTAL SHEETS: [REDACTED]
 DRAWING TITLE: [REDACTED]



2'-0" x WIDTH OF LANE

14'-0"

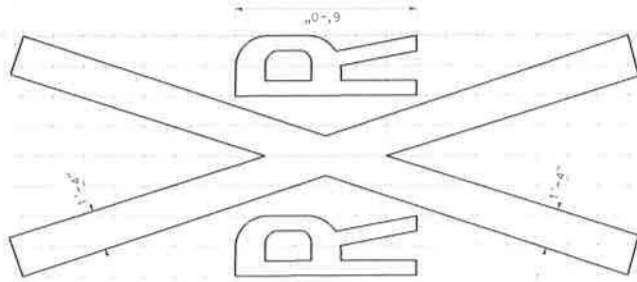

8'-0"

20'-0"

RR

14'-0"



2'-0" x WIDTH OF LANE

1'-0" GRID
A=70 f+2 *

RAILROAD CROSSING SYMBOL

* 70 f+2 does not include the 2'-0" x variable width transverse lines.

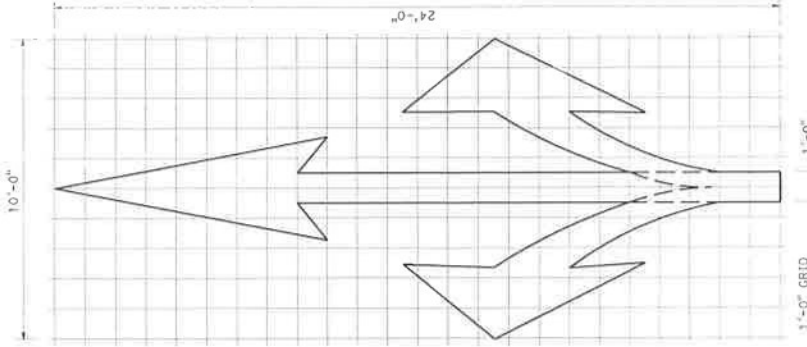

10'-0"

24'-0"

1'-0" GRID
1'-0"

A=59 f+2

TYPE II (B) ARROW

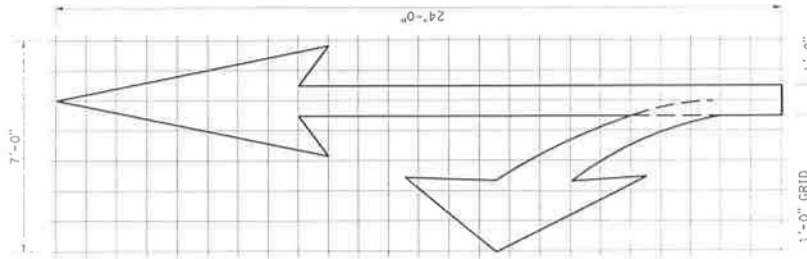

7'-0"

24'-0"

1'-0" GRID
1'-0"

A=45 f+2

TYPE II (L) ARROW

(For Type II (R) use mirror image)

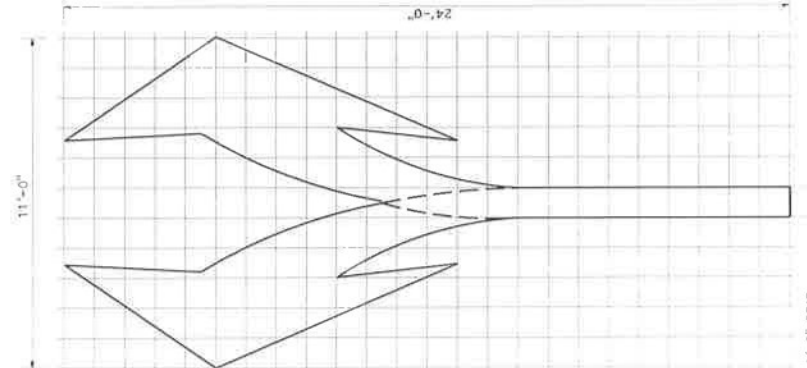

11'-0"

24'-0"

1'-0" GRID
1'-0"

A=73 f+2

TYPE III (B) ARROW

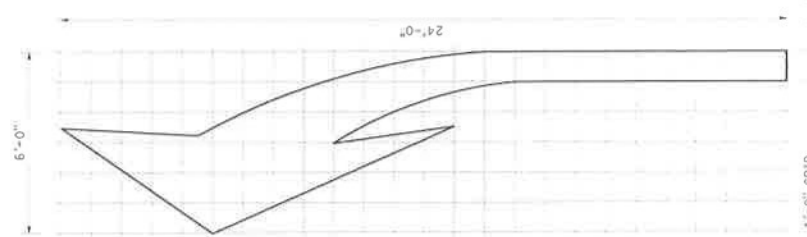

6'-0"

24'-0"

1'-0" GRID
1'-0"

A=42 f+2

TYPE III (L) ARROW

(For Type III (R) use mirror image)

NOTE:

Minor variations in dimensions may be accepted by the Engineer.

A24B

Return to Table of Contents

Clayton Farnsworth

 May 31, 2018

 CIVIL ENGINEER

NOTE:
Minor variations in dimensions may be accepted by the Engineer.

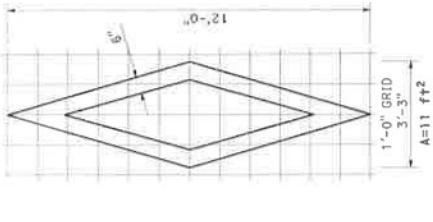

DIAMOND SYMBOL

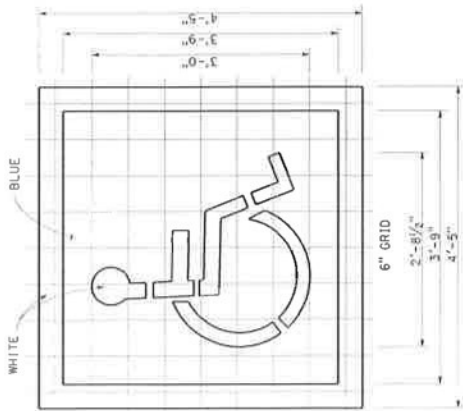

INTERNATIONAL SYMBOL OF ACCESSIBILITY (ISA) MARKING

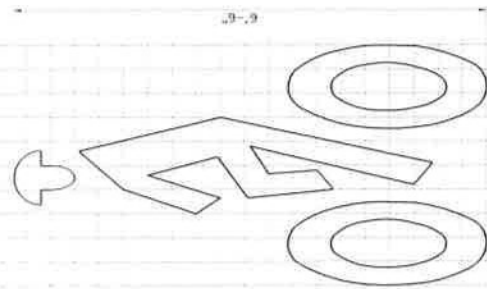

BIKE LANE SYMBOL WITH PERSON

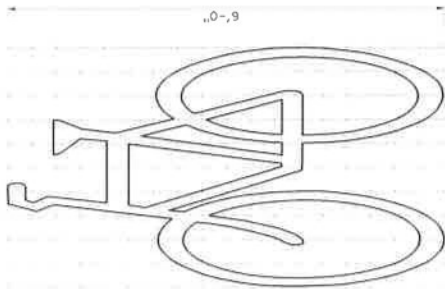

BIKE LANE SYMBOL WITHOUT PERSON

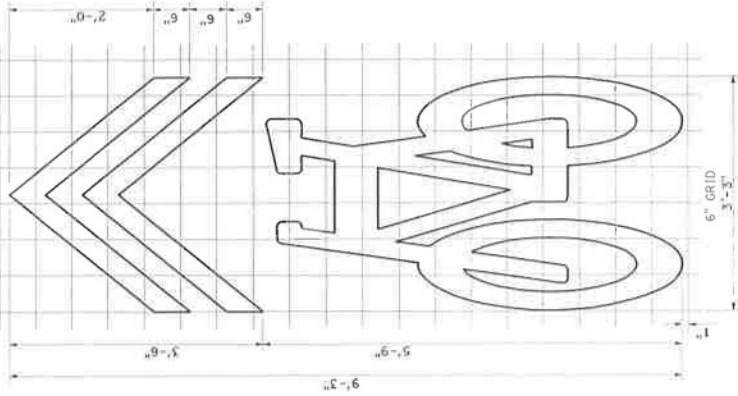

SHARED ROADWAY BICYCLE MARKING

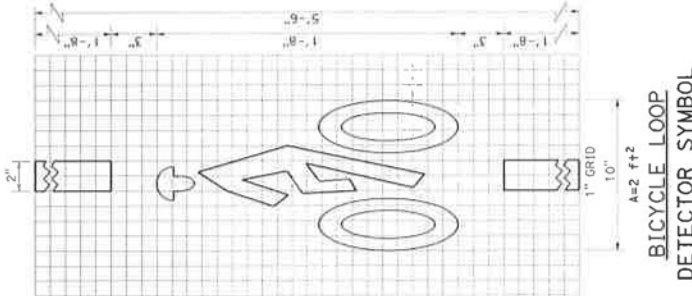

BICYCLE LOOP DETECTOR SYMBOL

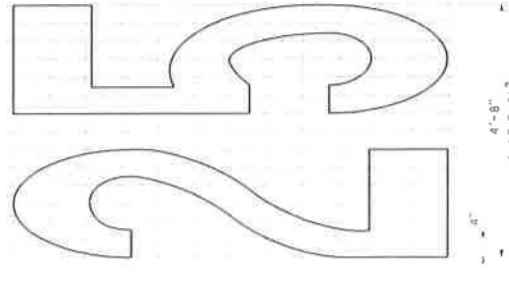
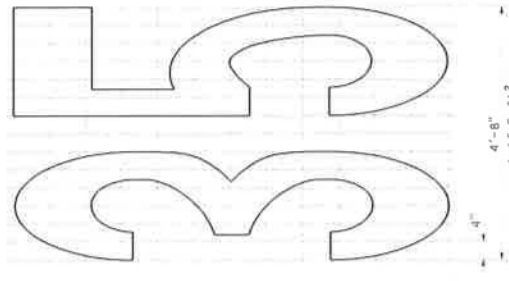
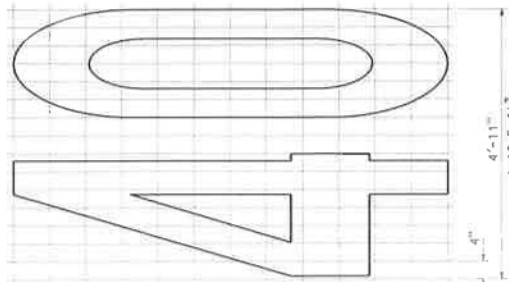

NUMERALS

STATE OF CALIFORNIA
DEPARTMENT OF TRANSPORTATION

PAVEMENT MARKINGS SYMBOLS AND NUMERALS

NO SCALE

A 24C



 May 31, 2018

RUNAWAY VEHICLES
 WAT
 A=43 ft+2

YIELD SLOW
 WAT
 A=23 ft+2

TURN HERE
 WAT
 A=24 ft+2

AHEAD
 WAT
 A=42 ft+2

SCHOOL
 WAT
 A=31 ft+2

SIGNAL LEFT
 WAT
 A=35 ft+2

COMPACT
 WAT
 A=10 ft+2

WAT
 A=19 ft+2

WAT
 A=26 ft+2

WAT
 A=24 ft+2

WAT
 A=26 ft+2

WAT
 A=31 ft+2

WAT
 A=19 ft+2

WAT
 A=10 ft+2

WAT
 A=21 ft+2

WAT
 A=18 ft+2

WAT
 A=22 ft+2

WAT
 A=26 ft+2

WAT
 A=26 ft+2

WAT
 A=19 ft+2

WAT
 A=10 ft+2

WAT
 A=6 ft+2

WAT
 A=5 ft+2

WAT
 A=6 ft+2

WAT
 A=5 ft+2

WAT
 A=5 ft+2

WAT
 A=10 ft+2

WAT
 A=10 ft+2

- NOTES:**
- If a message consists of more than one word, it must read "UP", i.e., the first word must be nearest the driver.
 - The space between words must be at least four times the height of the characters for low speed roads, but not more than ten times the height of the characters. The space may be reduced appropriately where there is limited space because of local conditions.
 - Minor variations in dimensions may be accepted by the Engineer.
 - Portions of a letter, number or symbol may be separated by connecting segments not to exceed 2" in width.

WORD MARKINGS					
ITEM	ft+2	ITEM	ft+2	ITEM	ft+2
XING	21	YIELD	24	BIKE	5
AHEAD	31	SCHOOL	35	SLOW	23
WAIT	19	SIGNAL	32	STOP	22
LANE	6	TURN	24	LEFT	19
RIGHT	26	HERE	26	VEHICLES	42
				PED	18
				COMPACT	10
				RUNAWAY	43
				VEHICLES	42

STATE OF CALIFORNIA
 DEPARTMENT OF TRANSPORTATION
PAVEMENT MARKINGS
WORDS
 NO SCALE

A 24D

© 2018 California Department of Transportation
All Rights Reserved

COUNTY: _____ PROJECT: _____ SHEET NO.: _____ TOTAL SHEETS: _____
 DATE: October 19, 2018
 DRAWN BY: _____ CHECKED BY: _____
 DESIGNED BY: _____
 APPROVED BY: _____
 TITLE: _____
 SCALE: _____
 PROJECT NO.: _____
 SHEET NO.: _____

TO ACCOMPANY PLANS DATED _____

ITEM	ft+2	ITEM	ft+2
LANE	24	NO	14
POOL	23	BIKE	21
CAR	17	BUS	20
CLEAR	27	ONLY	22
KEEP	24	FWY	16
HOV	18	EXPRS	30
TRAIL	23		

NOTES:

- If a message consists of more than one word, neglect the driver, i.e., the first word must be neglected.
- The space between words must be at least four times the height of the characters for low speed roads, but not more than ten times the height of the characters. The space may be made smaller if the road conditions are limited by the engineer.
- Minimum dimensions in dimensions may be accepted by the engineer.
- Portions of a letter, number or symbol may be neglected if the resulting segments do not exceed 20% in width.
- The words "NO PARKING" movement markings to be used for parking facilities for special locations of markings, see Standard Plans A90A and A90B.
- The words "NO PARKING" shall be printed in white letters no less than 1.0" high on 0.15" thick background and located so that it is visible to trailing enforcement officials.

LANE A=24 ft+2
 POOL A=23 ft+2
 CLEAR A=27 ft+2
 KEEP A=24 ft+2
 BIKE A=21 ft+2
 BUS A=20 ft+2
 ONLY A=22 ft+2
 FWY A=16 ft+2
 NO A=14 ft+2
 CAR A=17 ft+2
 HOV A=18 ft+2
 TRAIL A=23 ft+2
 EXPRS A=30 ft+2
 NO PARKING A=2 ft+2
 See Notes 5 and 6

STATE OF CALIFORNIA
DEPARTMENT OF TRANSPORTATION

PAVEMENT MARKINGS WORDS

NO SCALE

RSP A24E DATED OCTOBER 19, 2018 SUPERSEDES STANDARD PLAN A24E
DATED MAY 31, 2018 - PAGE 21 OF THE STANDARD PLANS BOOK DATED 2018.

REVISED STANDARD PLAN RSP A24E

DATE	PROJECT	SCALE	DATE	PROJECT	SCALE

Clayton Jensen
 REGISTERED CIVIL ENGINEER
 No. 45262
 May 31, 2018
 No. 2-31-18
 No. 2-31-18
 No. 2-31-18
 No. 2-31-18

NOTES:

1. Spaces between markings must be placed in wheel tracks of each lane.
2. Spacings not to exceed 2.5 times width of longitudinal line.
3. All crosswalk markings must be white except those near schools must be yellow.

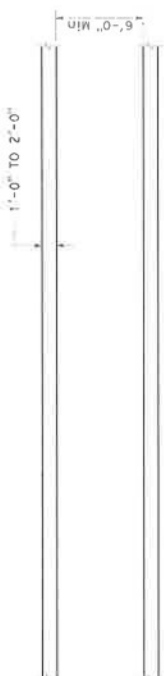
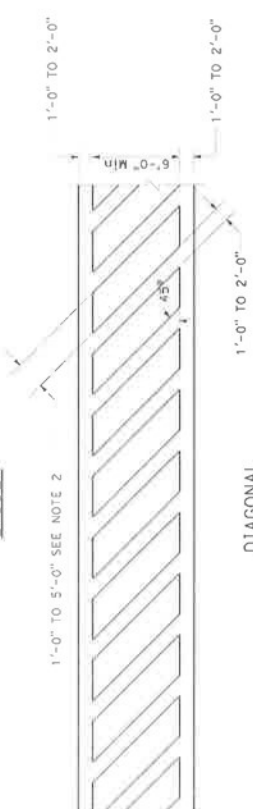
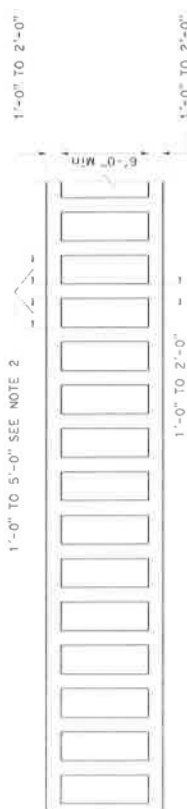
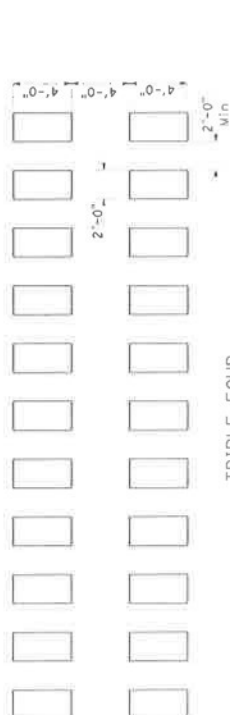
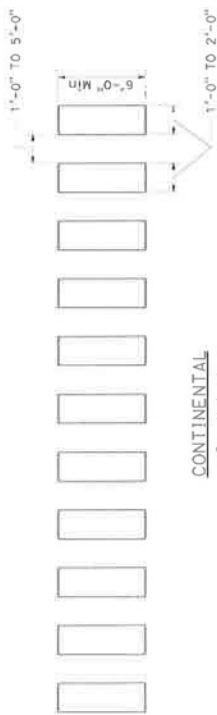

HIGHER VISIBILITY CROSSWALKS

STATE OF CALIFORNIA
 DEPARTMENT OF TRANSPORTATION
**PAVEMENT MARKINGS
 CROSSWALKS**

NO SCALE

A24F

© 2021 California Department of Transportation
All Rights Reserved

STATE	COUNTY	ROUTE	POST MILES	POST MILES TO NEXT PLAN

A. J. Farnsworth
 REGISTERED CIVIL ENGINEER
 April 16, 2021
 PLAN APPROVAL DATE
 RSP A24G SHALL BE USED IN ACCORDANCE WITH THE 2018 STANDARD PLANS BOOK, CHAPTER 13 OF STANDARD PLANS.

TO ACCOMPANY PLANS DATED _____

LEGEND:
MARKERS

TYPE R ONE-WAY RED RETROREFLECTIVE

MARKER DETAILS

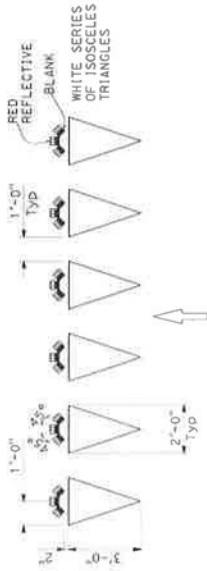
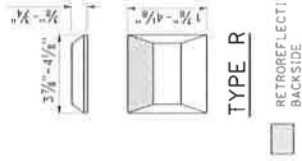

YIELD LINE AT EXIT RAMP

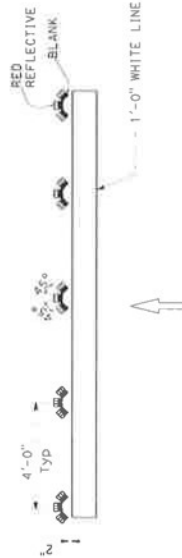

LIMIT LINE (STOP LINE) AT EXIT RAMP

NOTE:

1. If there is crosswalk at the end of the exit ramp, place Type R markers in the crosswalk with the red reflective side facing the intersection.



LIMIT LINE (STOP LINE)

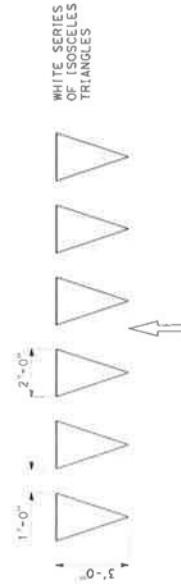

YIELD LINE

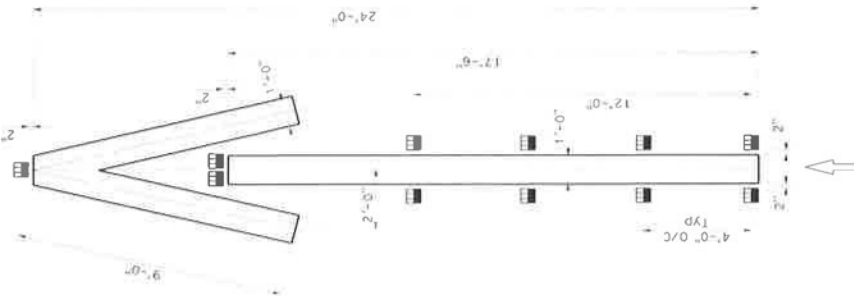

TYPE V ARROW AT EXIT RAMP

A=33 f42

STATE OF CALIFORNIA
DEPARTMENT OF TRANSPORTATION

**PAVEMENT MARKINGS
YIELD LINES, LIMIT LINES,
AND WRONG WAY DETAILS**

NO. SCALE

RSP A24G DATED APRIL 16, 2021 SUPERSEDES RSP A24G
DATED OCTOBER 19, 2018 THAT SUPPLEMENTS THE STANDARD PLANS BOOK DATED 2018.

REVISED STANDARD PLAN RSP A24G